



# Practice Workbook

This workbook is designed for use in Live instructor-led training and for OnDemand self-study. The explanations and demonstrations are provided by the instructor in the classroom, or in the OnDemand eLectures of this course available on the Bentley LEARNserver ([learn.bentley.com](http://learn.bentley.com)).

This practice workbook is formatted for on-screen viewing using a PDF reader. It is also available as a PDF document in the dataset for this course.

## AccuDraw Basics

In this course, you will learn:

- The Need of a reference frame and how AccuDraw provides it
- How to invoke and alter AccuDraw behavior with Settings and Shortcuts
- How to relocate and reorient coordinate frames in 2D and 3D using AccuDraw

TRNC03400-1/0001

## AccuDraw Basics

In this course, we will learn

- The **Need** of a reference frame and how AccuDraw provides it
  - **How** to invoke and alter AccuDraw behavior with Settings and Shortcuts
  - **How** to relocate and reorient coordinate frames in 2D and 3D using AccuDraw
- 

### Why do we need AccuDraw?

Almost all engineering projects create and use CAD data in the form of 2D drawings and 3D models. Precision and speed in this process are vital for a successful and timely project delivery. Though the domain and intent of the CAD data vastly varies, its underlying geometry has the common needs of precise *location, distances* and *directional inputs*. AccuDraw adds both *precision* and *speed* to the input process and offers ease of navigation in 2D and 3D space. Additionally, it provides a handy access to many other tools, settings and functionalities.

### Coordinate Reference Frames

The above requirement of specifying *Locations* and *Directions*, needs a reference point (called the *Origin*) and some reference directions (called *Coordinate Axes*). Together, these form a *Coordinate Reference Frame* (also called *Coordinate System* for short).

Further, a scale and a system of units must be adopted to numerically express the distances and angles.

Based on the problem domain and the design needs, the designer can choose from a wide choice of reference frames. Two of the most commonly used systems are

1. **Rectangular Coordinate System**
2. **Polar Coordinate System**

In real life, sometimes these coordinate systems are seen in city layouts. Some use a grid of streets and avenues forming a rectangular coordinate frame, while others use sets of radial and ring roads forming a polar coordinate system. They are then labeled so that any location in the city gets a unique address (*Coordinates*).

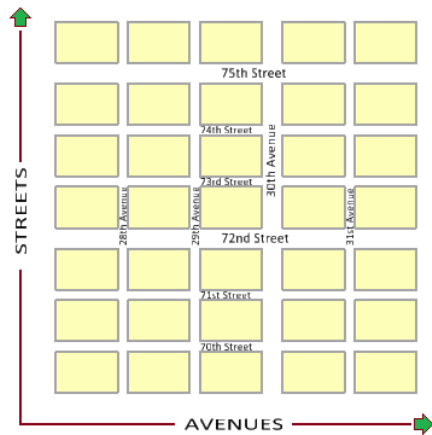

[a]

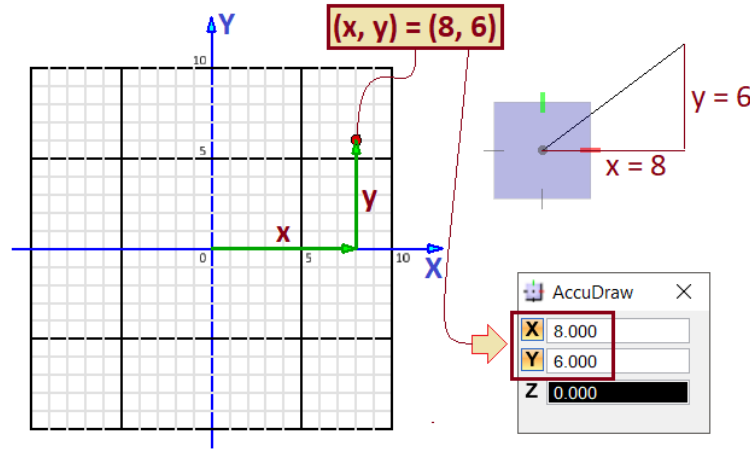

[b]

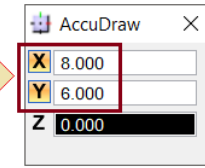

[c]

[a] A township using rectangular coordinate frame [b] Rectangular coordinates (x,y) of a point [c] AccuDraw Rectangular mode

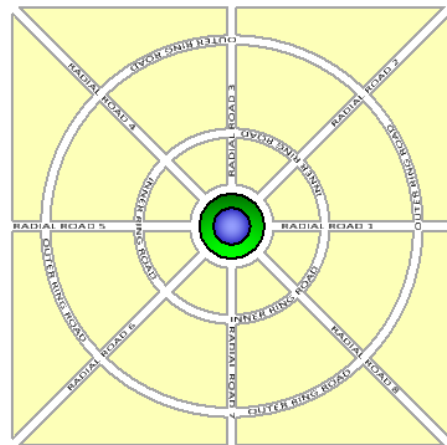

[a]

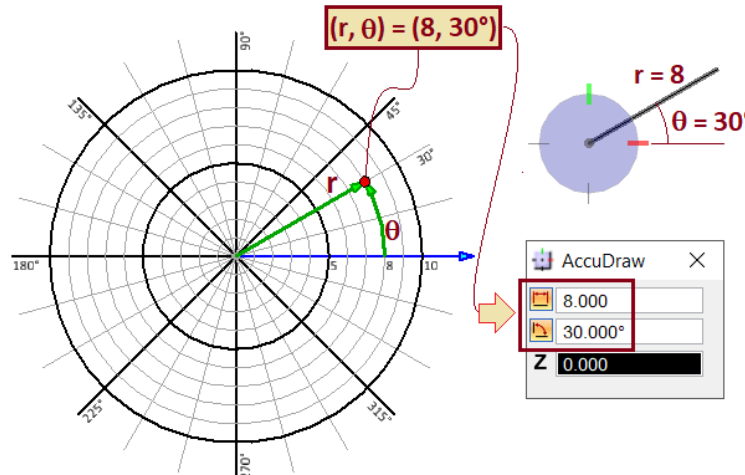

[b]

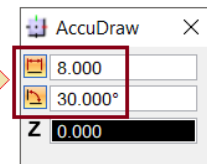

[c]

[a] A township using polar coordinate frame [b] Polar Coordinates (r, theta) of a point [c] AccuDraw Polar mode

### Rectangular Coordinate System

has two (three in 3D) perpendicular axes called the X, Y (and Z) axis meeting at the *Origin*. A point can be specified in terms of its distances from the Y and X axes, called the x and y coordinates respectively.

### Polar Coordinate System

specifies a point, in terms of its distance (r) from the origin and the direction of the line that connects it to the origin. This direction is specified as an angle ( $\theta$ ) made by that line with a reference direction as shown.

In 3D, a Z axis is added normal to the plane of the polar coordinate frame.

AccuDraw supports both these coordinate systems to reckon distances, directions and coordinates.

## Components of AccuDraw

AccuDraw has two main components –

1. **AccuDraw Compass** – This visually depicts the current coordinate frame that AccuDraw is using in the design file. It shows its location (origin), the orientation (reference axes) and the plane defined by them. The shape of the compass indicates the mode as shown.

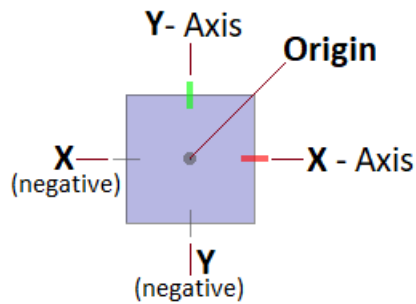

[a]

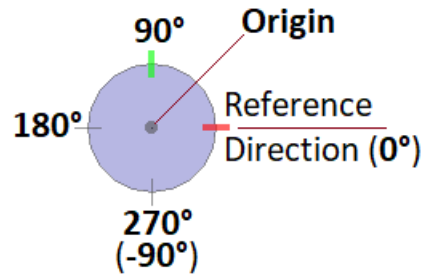

[b]

**AccuDraw Compass: in [a] Rectangular and [b] Polar mode**

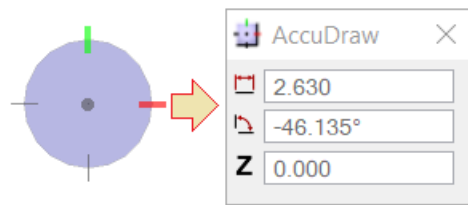
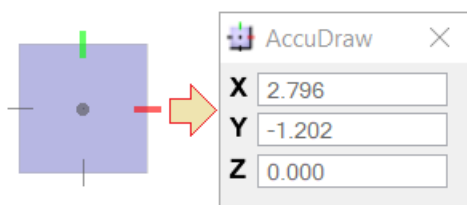

**AccuDraw Shortcuts** can accomplish multiple tasks. They can control AccuDraw compass's location, orientation, mode etc. or access other tools and functionalities like Ribbon groups, Snaps etc. For these shortcuts to reach

its location (origin), the orientation (reference axes) and the plane defined by them. The shape of the compass indicates the mode as shown.

2. **AccuDraw Coordinate Window** – It provides a two-way communication – input as well as output.

The coordinate window -

- a. **Displays coordinates** numerically
- b. **Accepts inputs** – distances, angles etc.
- c. Accepts short, alphanumeric key-ins called **AccuDraw Shortcuts**

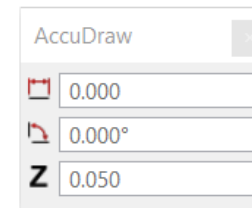

**Without Focus**

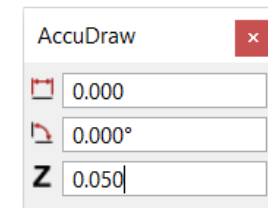

**With Focus**

AccuDraw, the AccuDraw Coordinate Window must have the *Focus*. Click in it to give it the Focus, which is then apparent from the look of the Coordinate Window as shown.

**Keyboard Shortcuts and Focus:** Besides AccuDraw Coordinate Window, other entities like Tool Settings window, Key-In Window, Search Text Box etc. are also capable of accepting an input from the keyboard. The intended recipient of the input can be selected by clicking in it *prior* to the input. This transfers the *Focus* to the recipient sending the subsequent inputs to it.

### AccuDraw Settings

Besides the Compass and Coordinate Window, AccuDraw has a settings dialog from which its behavior and look and feel can be changed. Key-in shortcut **GS** in Coordinate Window to open it. It has three tabs – *Operation*, *Display* and *Coordinates*.

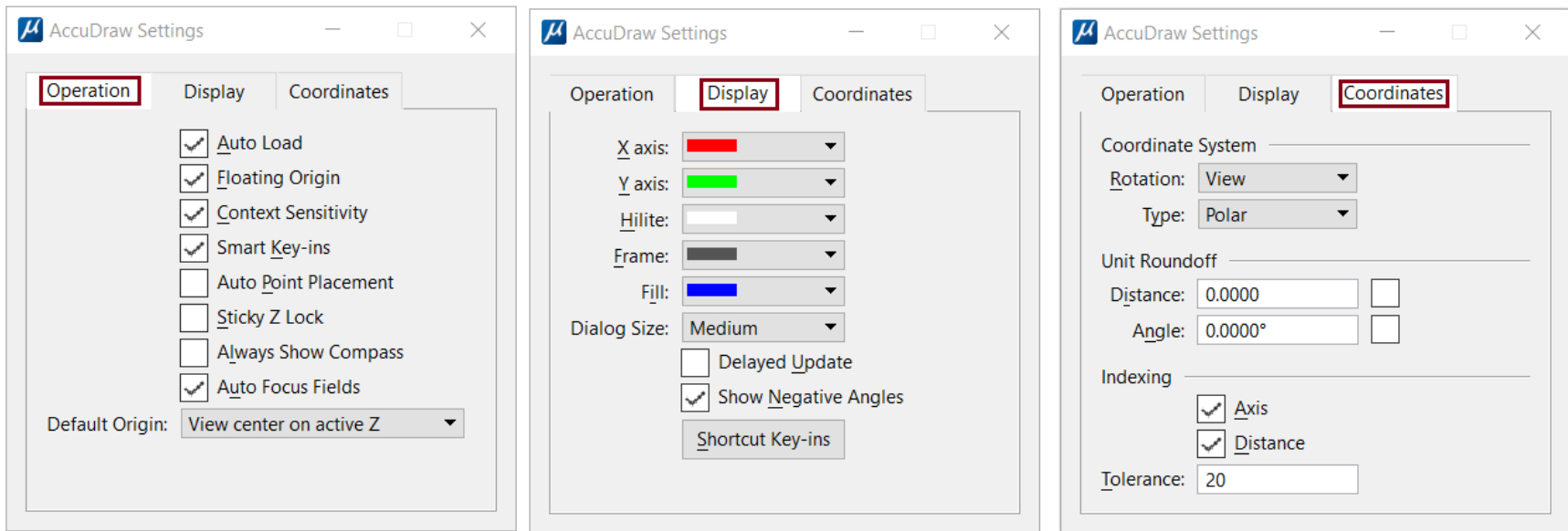

### Accessing AccuDraw

AccuDraw can be toggled ON/OFF and its settings can be accessed from the **Drawing Aids** tab of the ribbon in any workflow (**Drawing / Modeling / Rendering**).

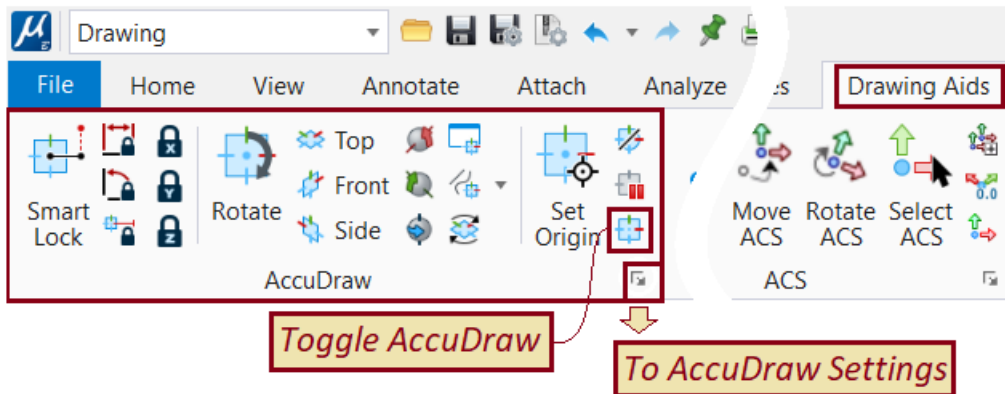

Some of the settings can also be changed from the Ribbon. Or the settings dialog itself can be accessed from the Ribbon. The hands-on exercises that follow cover all the basic settings and shortcuts.

**Index of Hands on Exercises** - click any link to directly go to any exercise

Link	DGN Model	Shortcuts & Settings	Description
<a href="#">Exercise 1a</a>	Ex 1 Walkway and Graph	GS, M, Floating Origin ON, Smart Key-Ins, Indexing	Open settings, Change mode, locking distance and axis
<a href="#">Exercise 1b</a>	Ex 1 Walkway and Graph	O, Floating Origin OFF, Auto Point Placement	Fixing/Relocating origin, Entering coordinates for point placement
<a href="#">Exercise 2</a>	Ex 2 Door Frame	'(Accent), Enter, V, Context Sensitivity ON	Bump tool settings, Locking axis, Aligning compass to View,
<a href="#">Exercise 3</a>	Ex 3 Ramp Railing	RQ	Arbitrary rotation of compass in its own plane
<a href="#">Exercise 4</a>	Ex 4 3D Text Labels	C, T, F, S, V, E	Accessing snaps, standard compass planes and cycling through them
<a href="#">Exercise 5</a>	Ex 5 Elbow for Pipes	RX, RY, RZ	Rotating compass about its own X, Y, Z axes. Reorient a cell being placed
<a href="#">Exercise 6</a>	Ex 6 Geodesic Dome	RA, WA, GA	Arbitrary compass rotation in 3D. Creating, saving and recalling an ACS

**Exercise 01 a:** Creating a walkway around a structure ..... [Back to Top](#)

Settings *Floating Origin ON, Smart Key-ins, Indexing (Distance, Axis)*

Shortcuts *GS, M*

1. Open the File **Basic Exercises.dgn**
2. Open the Model **Ex 1 Walkway and Graph** *In the upper half, the sketch of a pathway to be created around a structure and its dimensions is shown. It is to be plotted on the right from the start point **A** to the endpoint **G**.*

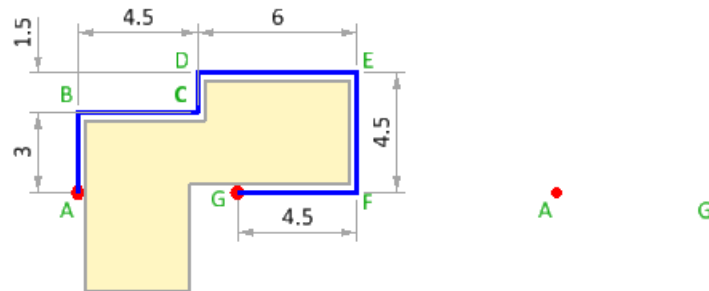

3. In the **Coordinate Window** keyin Shortcut **GS** to open the Settings dialog.
4. In the **Operation** Tab, make sure the **Floating Origin** and **Smart Key-ins** CheckBoxes are ON
5. Start the **SmartLine** tool, from the **Placement** tab of **Drawing** workflow.

① Click a Data Point at A. *This starts a Line String. Note this also places the Compass at A due to **Floating Origin** being ON*

If AccuDraw is in the polar mode (where compass appears as a circle), use Shortcut **M** to toggle the mode to rectangular (where compass appears as a square).

② Move the cursor in a direction closer to the horizontal (X) *Note the X coordinate filed in the Coordinate Window gets highlighted, indicating that it has the focus and thus any numerical value typed would go there.*

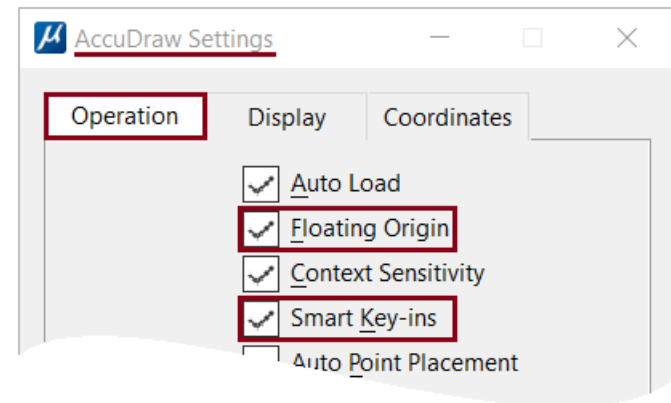

- 3 Now, move the cursor in a direction closer to the vertical (Y) Note the focus automatically shifts to the Y field of the Coordinate Window. This is due to the **Smart Key-ins** setting, which senses the direction and automatically shifts the focus, to direct numerical inputs to the appropriate field.

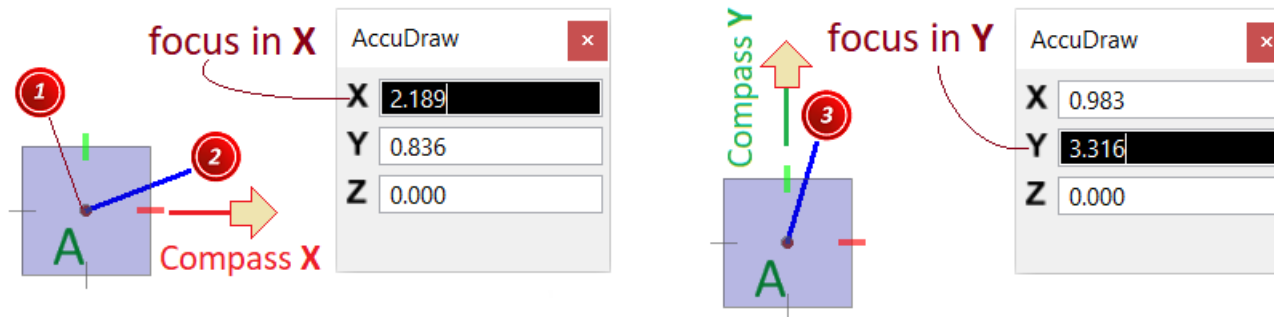

**Smart Key-Ins:** Shifts the focus to the X or Y coordinate TextBox, when the cursor is closer to the corresponding axis (X or Y) of the AccuDraw Compass respectively.

- Move the cursor closer to the Y axis, note the line 'snaps' to it, even before the cursor reaches there. This is **Indexing to the Axis** - a setting in the Coordinates tab.

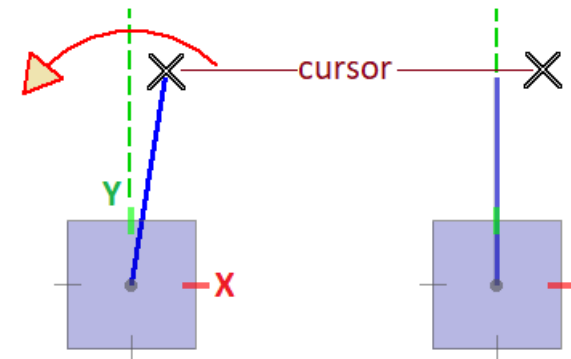
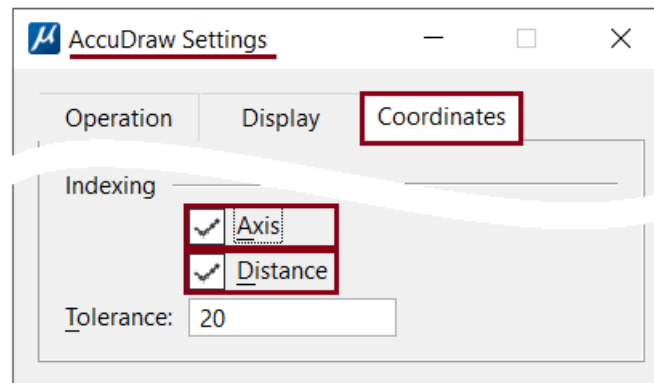

**Indexing:** when the cursor is within a certain distance from the X or Y axis, the direction aligns or 'indexes' to it

- Type the numeral 3 and click a data point. *This automatically goes in the Y field because of **Smart Key-ins** and the vertical segment AB of length 3 gets placed. Note, due to **Floating Origin**, the Compass now moves to point B just clicked.*

Following Table summarizes the steps for completing the walkway.

**Floating Origin** helps, because all distances are specified from the previous point

**Smart Key-ins** make sure the values typed in automatically go to the appropriate field.

**Indexing** gives the horizontal and vertical directions precisely and effortlessly. Together they add to the speed and overall efficiency.

Move in the <b>Direction</b>	key-in the <b>Distance</b>	to reach the <b>Point</b>
Upward	3	B
Rightward	4.5	C
Upward	1.5	D
Rightward	6	E
Downward	4.5	F
Leftward	4.5	G

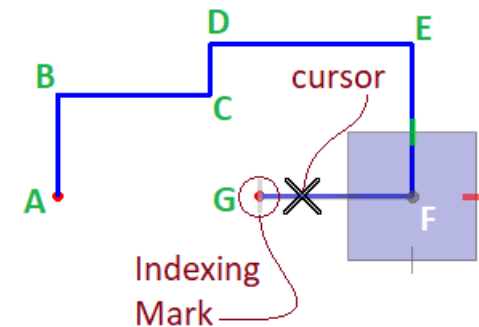

Lengths:  $EF = 4.5 = FG$

**Indexing (Distance):** 'Remembers' the last distance plotted and 'indexes' to it when close, indicating it with a mark.

**Indexing (Distance):** Note while placing the last segment FG, the line 'leaps' or 'indexes' to point G even before the cursor reaches there! This is because AccuDraw 'remembers' the last distance plotted (length of segment EF = 4.5) and indexes to it when close. So, no need to key in the distance if it is same as the last one. This adds to the speed and efficiency of course!

**Exercise 01 b:** Plotting a line graph..... [Back to Top](#)

Settings **Floating Origin OFF**, **Auto Point Placement ON**

Shortcuts **O**

1. Open the File **Basic Exercises.dgn**
2. Open the Model **Ex 1 Walkway and Graph** *In the lower half, a line graph is shown with a list of point coordinates it connects.  
This is to be redrawn on the right.*
3. In the **Operation** Tab of AccuDraw Settings, turn **Floating Origin** OFF

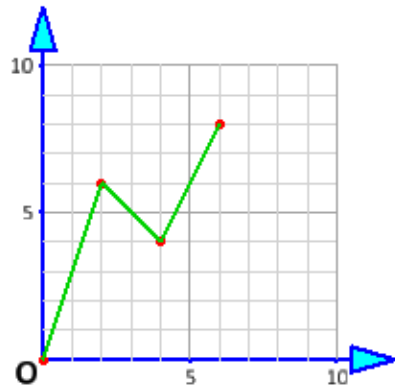

(0,0)  
(2,6)  
(4,4)  
(6,8)

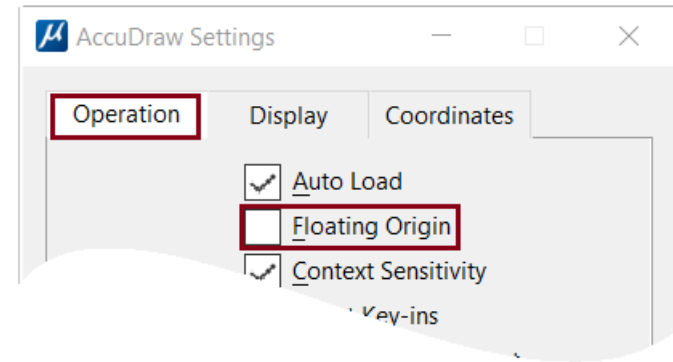
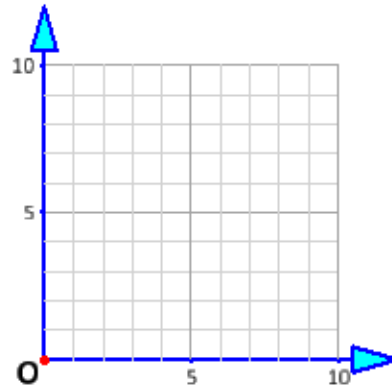

4. Start the **SmartLine** tool.

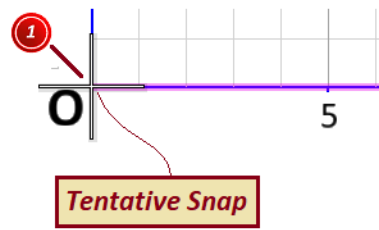
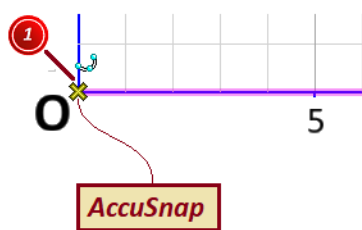

- 1 Snap to point O either with AccuSnap or a **Tentative Snap** (clicking the right and left mouse buttons together) *This precisely locates the cursor at point O.*
- 2 Type Shortcut **O** in the Coordinate Window. *This positions the Compass with Origin at O. This way the compass can be relocated anywhere the cursor is positioned!*



- 3 Click a Data Point at O. *This starts the Line String.*
- 4 In Coordinate Window, type the coordinates of the next point (2,6): 2 in X and 6 in Y filed respectively. *This shows a preview of a line segment from O(0,0) to (2,4).*

**Locking Coordinates:** Note, on entering the coordinate value the corresponding field label, X or Y gets highlighted, indicating it is **Locked** i.e. it's value will **not** change even if the cursor moves. In both rectangular and polar modes, the coordinates **X**, **Y**, **Z**, **Angle**, **Distance** can be locked with shortcuts **X**, **Y**, **Z**, **A**, **D** respectively.

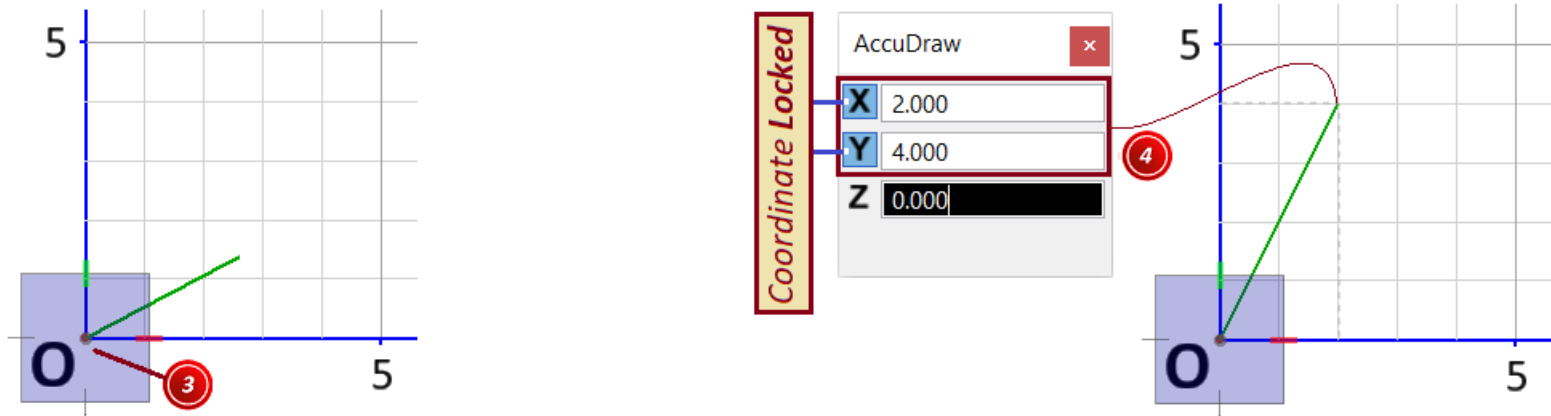

- 5 Accept the preview with a data point. *The segment gets placed. Note, the AccuDraw Compass **remains** at O, because **Floating Origin** is OFF. Hence any subsequent coordinate inputs would still be reckoned from point O.*
- 6 Similarly, type the next two points: (4,4) and (6,8) in Coordinate Window and accept to place them.

5. Reset to end the Line string.

**Auto Point Placement:** The above workflow of plotting a graph, can be further improved with the **Auto Point Placement** setting. This places the point with an **Enter** key instead of the left click.

## Reorienting the Compass

The power of **relocating** the AccuDraw Compass seen above, is further enhanced by the ability to **reorient** it. It can be done manually of course, but the setting **Context Sensitivity** can do it automatically, based on the geometry just plotted or to be plotted next. It can also switch the AccuDraw mode accordingly.

**Exercise 02:** Placing a door frame ..... [Back to Top](#)

Settings **Context Sensitivity ON**

Shortcuts ' (Accent or Backquote), Enter, V

1. Open the File **Basic Exercises.dgn**
2. Open the Model **Ex 2 Door Frame** It shows a door frame ABDEA with an arch and its key dimensions. It is to be redrawn on the right, where point A and the arch center C are given.
3. In the **Operation** Tab of AccuDraw Settings, make sure **Context Sensitivity** is turned ON

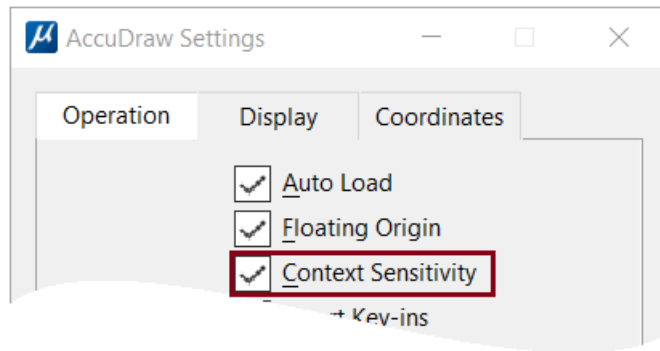
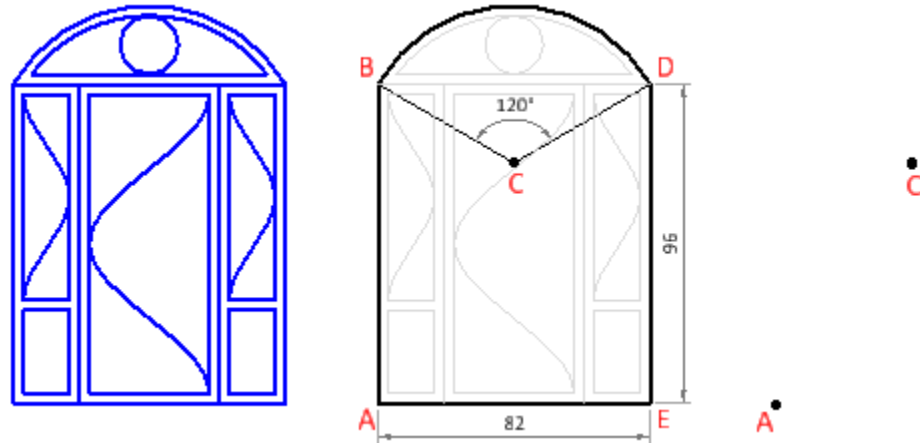

4. Start the **SmartLine** tool.

- 1 Click a data point at A. *This starts a Line String. [If needed] Switch to Rectangular mode with Shortcut M.*
- 2 Move upward, enter distance 96 and click a data point. *This places line AB.*
- 3 Type in AccuDraw Shortcut ( ` ) to **Bump Tool Settings**. *On the keyboard, this key is on the left of the number key (1). This shortcut cycles through the items in the topmost drop down list in the Tool Setting window. For SmartLine it is the Segment type, which toggles between Lines and Arcs.*

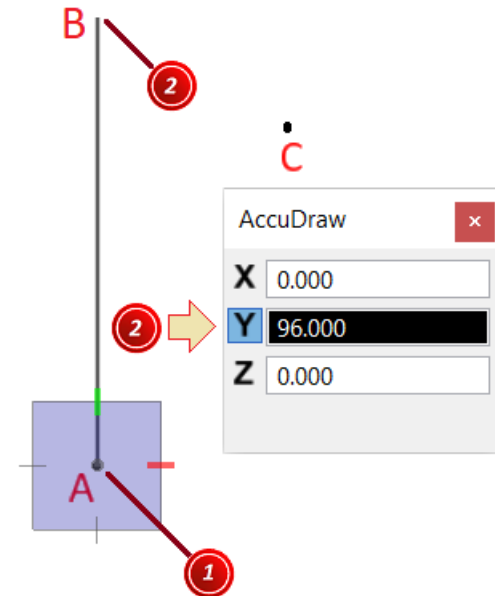
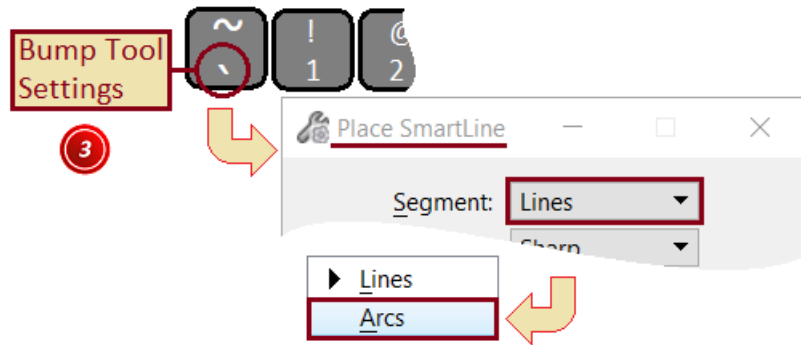

- 4 Snap to and click the given center C of the arc to be plotted. *Preview shows an arc with start point B and center C. The direction and sweep angle of the arc follows the cursor. Note **Context Sensitivity** has changed Compass mode to polar and has rotated the Compass to point the red 0° mark at the start point B, from which the arc's sweep angle will be measured.*

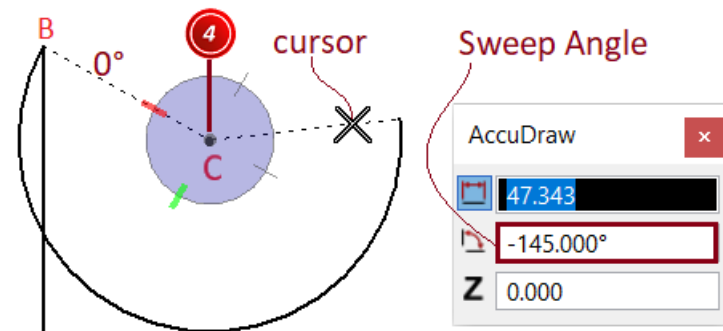

- 5 [If needed] move the cursor clockwise around the center to change the direction of the arc.

- 5 Without changing the negative sign, enter the required sweep angle 120 in the angle field of Coordinate Window and accept the arc with a data point. *This places the desired arc.*

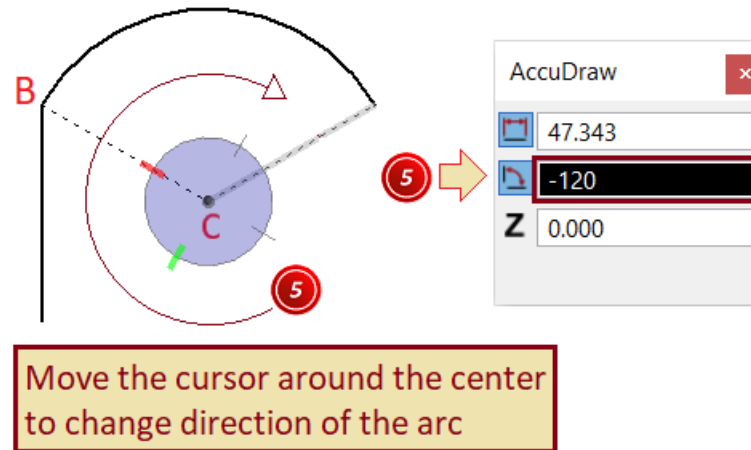

- 6 Use shortcut (V) again to change SmartLine segment back to Lines. Type shortcut (V for *View Rotation*) to align the compass axes to the view axes (vertical and horizontal). *This helps placing the vertical line. The mode may be left as polar or changed with shortcut M.*
- 7 Move the cursor vertically downward and press the Enter key. *This locks the line to the vertical (Y axis), even if the cursor may deviate.*
- 8 Snap to point A and click a data point. *This places segment DE, aligning E horizontally with A.*
- 9 Click a data point at A. *This completes the door frame.*

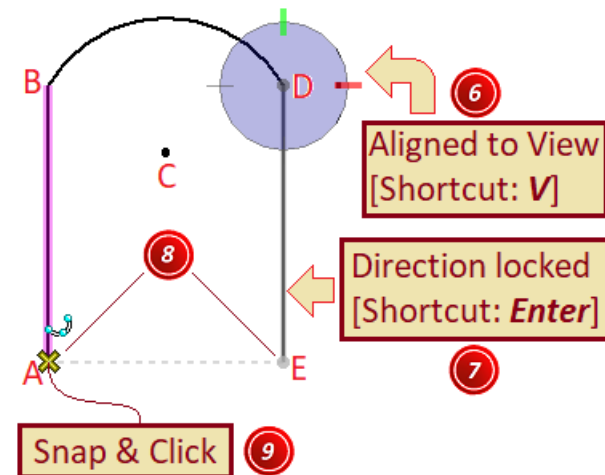

In the above exercise, compass rotation was triggered automatically by

*Context Sensitivity*. The next exercise covers the manual rotation of the axes in any desired direction.

**Exercise 03:** Completing a railing of a ramp ..... [Back to Top](#)

Shortcut **RQ**

1. Open the File **Basic Exercises.dgn**
2. Open the Model **Ex 3 Ramp Railing** On top it shows the railing of a ramp with 31 vertical supports (balusters) at a pitch of 0.75 as shown. A partially finished copy is given at the bottom, with only one baluster which is to be copied with correct spacing.

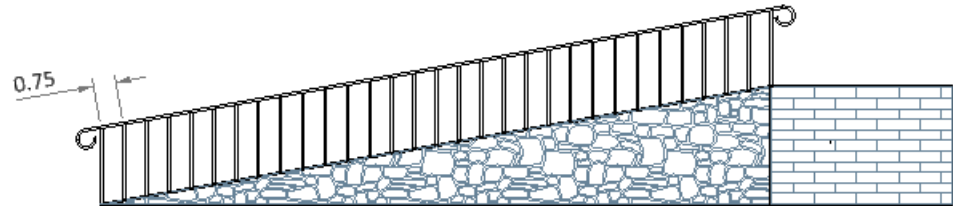

3. From the Right click menu, start the **Copy** tool,
  - 1 set Copies to 30
  - 2 select the baluster at its lower left vertex
  - 3 Type Shortcut RQ. This makes the compass rotate freely to follow the cursor.
  - 4 Snap to the midpoint or endpoint of the ramp. This aligns the Compass to the inclination of the ramp, along which the pitch (spacing of the balusters) is measured.
  - 5 Accept the orientation with a data point. This fixes the direction of the Compass Axes.

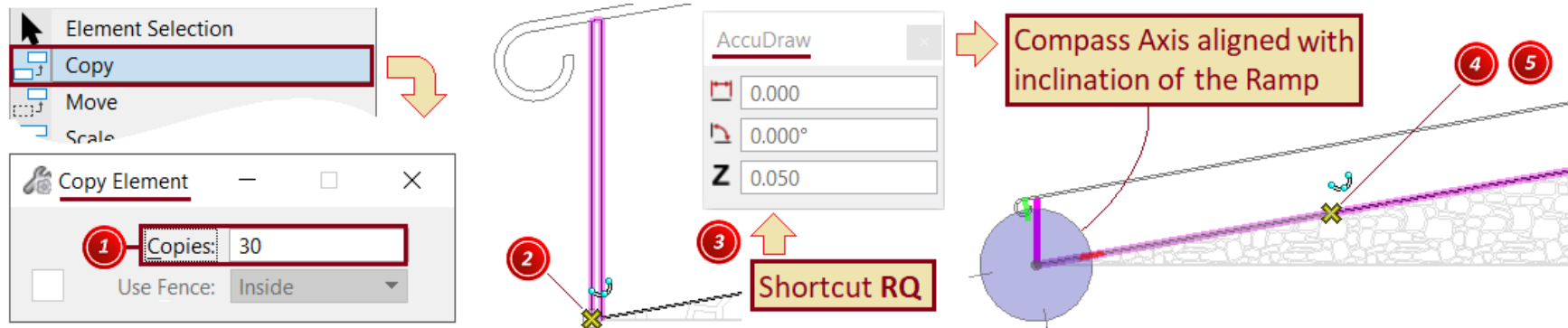

- 6 In the distance (or X if in rectangular mode) field of the Coordinate Window type the desired distance 0.75.

- 7 Snap to the mid-point or end of the ramp and accept. *This places 30 copies of the support at a 'pitch' of 0.75 along the ramp as required*

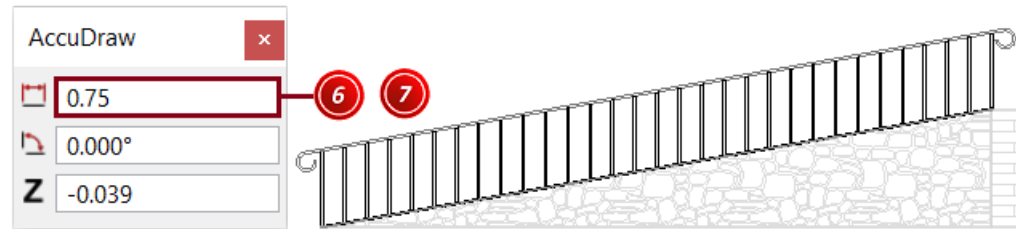

**Alternate Approach:** The arbitrary rotation of the Compass, can also be achieved from [Drawing/Modeling Workflow > Drawing Aids](#) Tab > [AccuDraw](#) Section > [Rotate](#) icon.

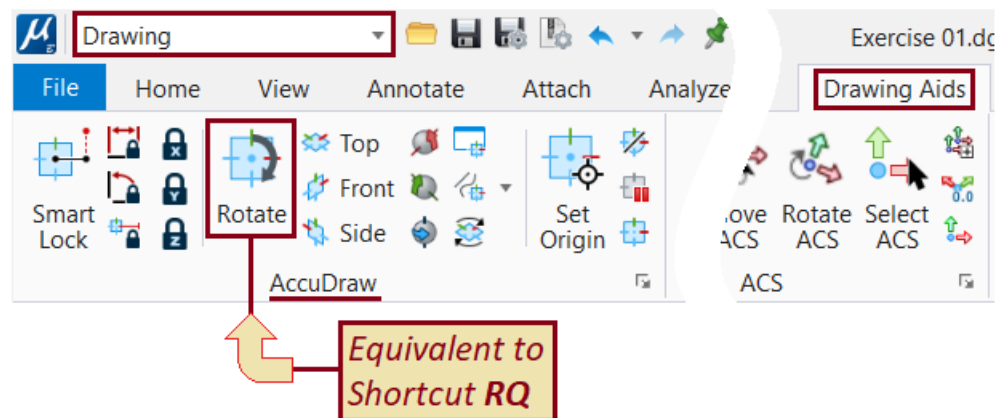

**Reorienting AccuDraw Compass Plane** While rotating the AccuDraw axes in the last exercise, the plane of the Compass did not change. But while working in 3D, reorienting the plane of the Compass is often necessary. It is covered in the next exercise.

**Standard Planes** The XY, YZ and ZX planes defined by the design axes (or planes parallel to them), are called the *Top*, *Side* and *Front* planes respectively as shown. AccuDraw compass plane can be quickly aligned to these orientations with Shortcuts *T*, *S* and *F*

respectively. Another frequently used plane - the *View* plane (plane of the screen, normal to our line of sight) can be aligned to with shortcut **V**.

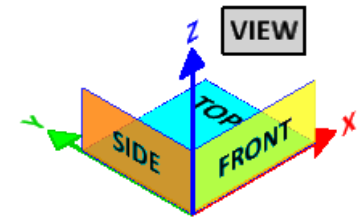

**Exercise 04: Labeling a 3D Model** ..... [Back to Top](#)

Shortcuts **C, T, F, S, V, E**

1. Open the File **Basic Exercises.dgn**
2. Open the Model **Ex 4 3D Text Labels**. *It shows a 3D model of a Separation Tank, where liquid from the incoming effluent is recovered and the slurry discharged. The three lines are to be labeled as shown. Note, the **planes** of the labels are different. These labels are to be placed in the model on the right.*
3. From **Drawing Workflow, Annotate Tab, Text section**, start the **Place Text Tool**. *This also opens the Text Editor window.*

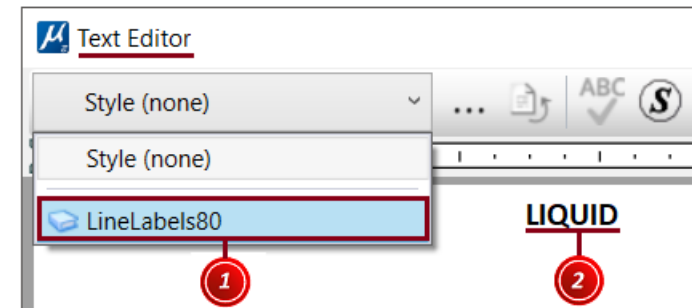
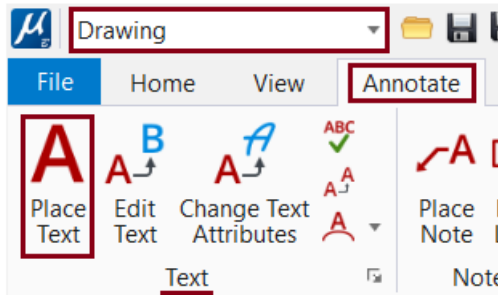
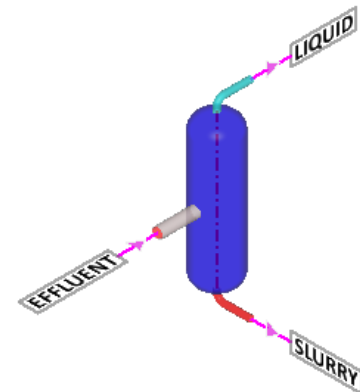

- 1 Set the Style to **LineLabels80**. *This style uses the center-center justification of text.*
- 2 Type the text "LIQUID" in the Text Editor.

- 3 Type Shortcut **C** in AccuDraw Coordinate Window. *This sets the Snap mode to Center.*
- 4 Snap to the rectangular boundary of this label. *This matches the center of the text with that of the rectangle, but its plane and orientation still may not match the plane of the rectangular boundary.*

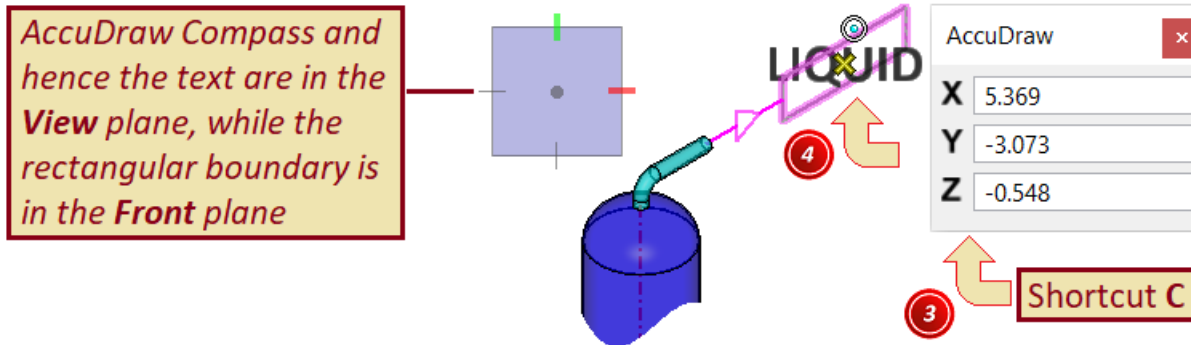

- 5 Type shortcut **F** in AccuDraw Coordinate Window. *This rotates the AccuDraw Compass, as well as the text to the front orientation.*
- 6 Accept. *This places the text with the correct location and orientation.*

4. Similarly, use shortcuts **C** and **T** to place text 'EFFLUENT' in the box provided.
5. Now type the text 'SLURRY', orient it with shortcut **S** (for *Side*) and snap (but do not accept) to the box center with shortcut **C**. *Note, the text center and plane are correct, but it is flipped about a vertical axis like a mirror image! It needs to be rotated by 180° about the Compass Y axis.*

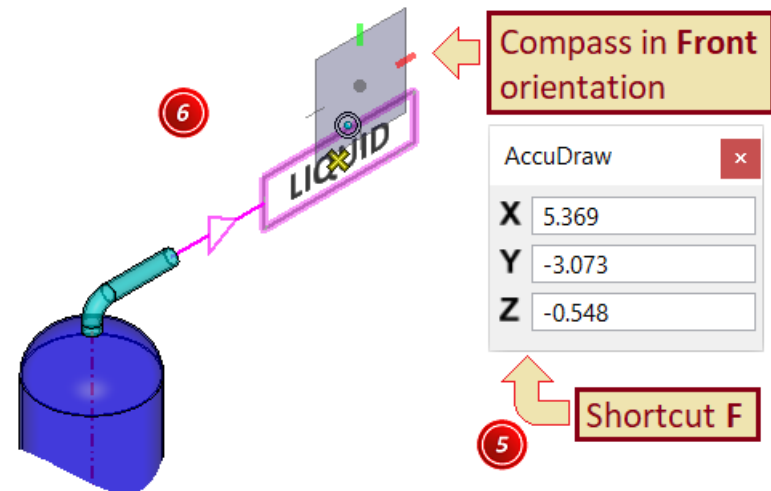

6. Type Shortcut **RY**. This rotates the compass (and thereby the text) by 90° about the Y axis.
7. Type Shortcut **RY** again. This rotates the compass by 90° more, amounting to a 180° flip giving the desired orientation.
8. Accept. The text gets placed.
9. Lastly, place text 'SEPARATION TANK' by orienting it to the View plane with shortcut **V**.

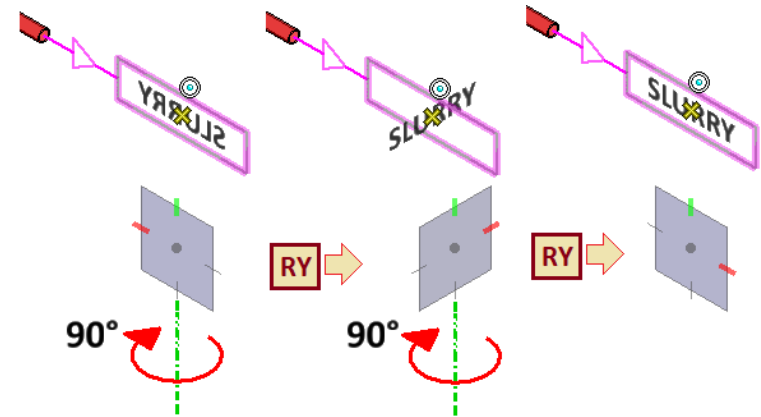

**Cycling through Standard Planes:** While working in an arbitrarily rotated 3D view, the Top, Side and Front plane orientations may not be readily recognizable. In such situation, one can cycle the compass plane through the three standard planes **T – F – S – T – F ...** with repeated use of shortcut **E** until the desired orientation is reached.

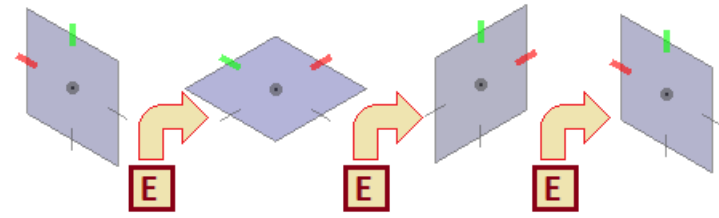

**AccuDraw and Snap Modes:** In the last exercise, the center snap was invoked with AccuDraw shortcut **C**. Snap modes per se are not part of AccuDraw functionality, but they can be readily set/changed with AccuDraw shortcuts **C** (Center), **N** (Near Point), **I** (Intersection) and **K** (Snap divisor). Thus AccuDraw acts as a ever present drawing aid.

1. **Exercise 05:** Connecting Pipes with an Elbow ..... [Back to Top](#)  
Shortcuts **RX, RY, RZ**
2. Open the File **Basic Exercises.dgn**

- Open the Model **Ex 5 Elbow for Pipes** It shows 3 mutually perpendicular pipes, whose center lines meet in a single point O. Any two of these three pipes can be connected with a 90° elbow.
- From Drawing Workflow, Home Tab, Placement section, start the Place Active Cell Tool. The tool setting shows 'Elbow' as the active cell, which is now attached to the cursor, ready for placement.

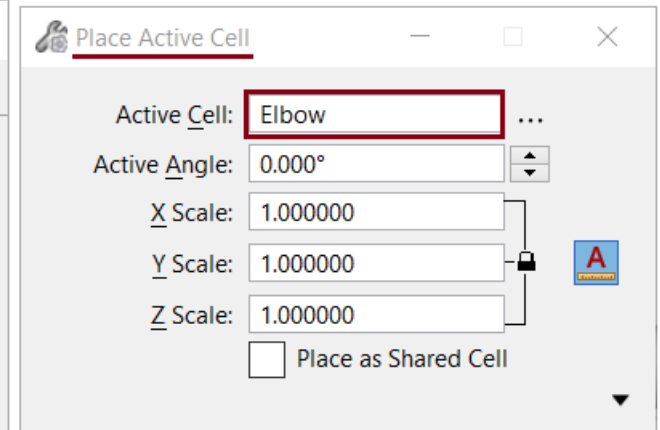
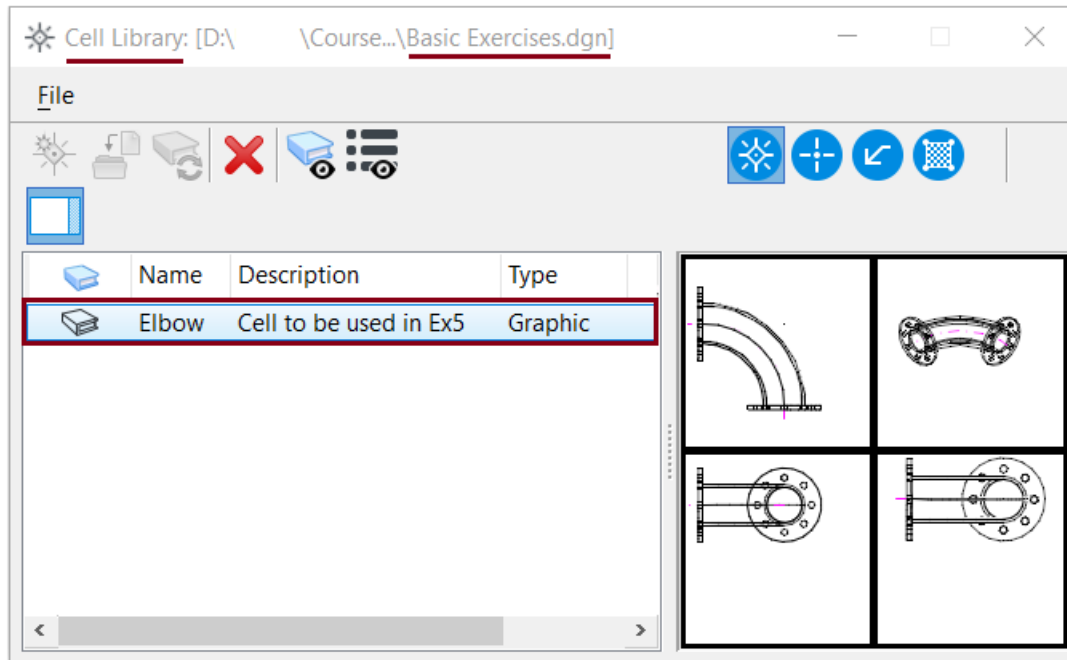
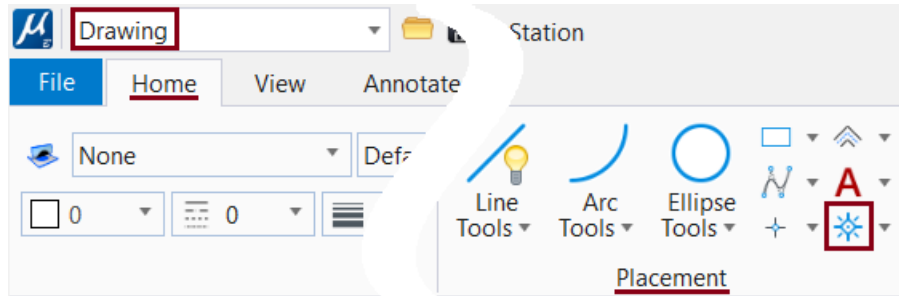
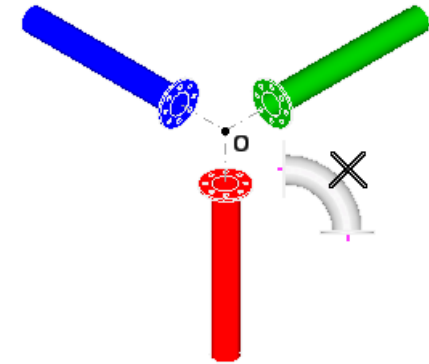

[If the 'Elbow' cell is not seen attached to the cursor] Attach the current file to itself as a cell library and double click the cell 'Elbow' in it.

- ❶ Snap to point **O** and with shortcut **O**, locate the compass there.
- ❷ With shortcut **T** align the compass to the top plane. *Note, this places the elbow in the plane of the blue and green pipes.*  
*But to connect the two, it must be rotated about the Z axis of the compass by 180°.*
- ❸ Type shortcut **RZ**. *It rotates the compass (and the elbow) by 90° about the Z axis of the compass.*
- ❹ Use shortcut **RZ** again and accept. *This rotates the elbow by another 90°, connecting the pipes and places it.*

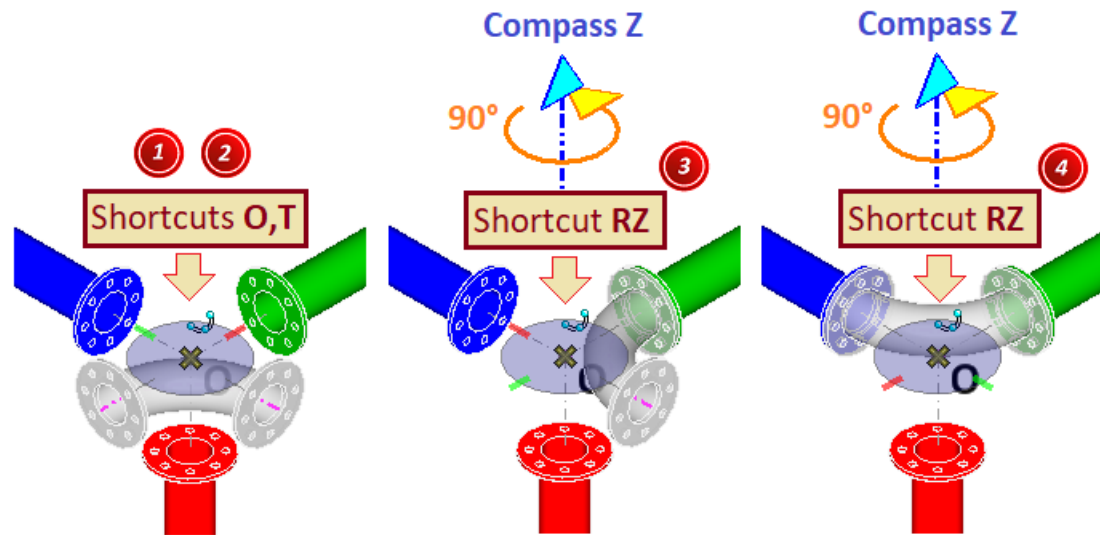

5. Similarly, an appropriate series of shortcuts **RX**, **RY** and **RZ** can be used to connect any two of the three pipes. There are virtually endless possible sequences. Here are two possible sequences starting from step ❶ above -
  - a. To connect the red and green pipe: **O, T, RZ, RY**
  - b. To connect the red and blue pipe: **O, T, RY, RX, RX**

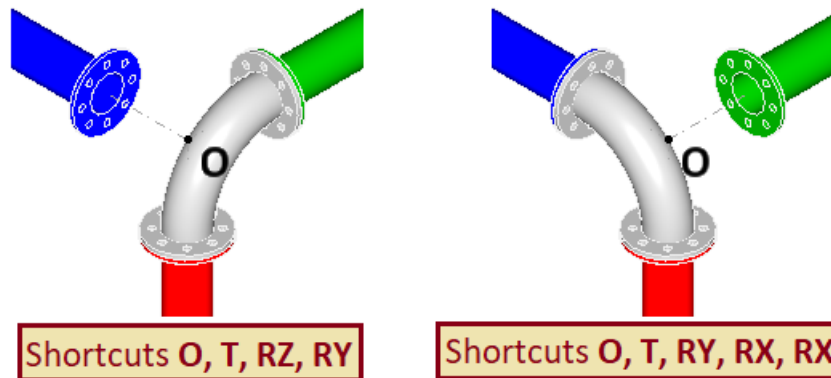

**Arbitrary Rotation in 3D:** So far, rotation of the compass in its own plane (RQ) or to the standard planes (T, F, S, V, E) and about its own axes (RX, RY, RZ) was covered. It is now time for the most general, arbitrary rotation/orientation of the Compass, enabling working in any imaginable plane in 3D! Further, such the coordinate frames in these orientations, can be saved and recalled later.

**Exercise 06:** Completing a Geodesic Dome ..... [Back to Top](#)

Shortcut **RA, WA, GA**

1. Open the File **Basic Exercises.dgn**
2. Open the Model **Ex 6 Geodesic Dome** *It shows a geodesic dome like pavilion. In its copy on the right, the missing polygonal panels and panes are to be added.*
3. From **Drawing Workflow, Home Tab, Placement** section, start the **Place Regular Polygon** Tool.

Set -

Method = *By Edge*

Edges = 6

Fill Type = *Outlined* *This allows a fill color different from the polygon boundary.*

Fill Color = 1

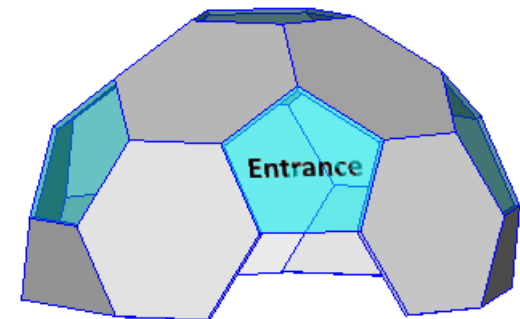

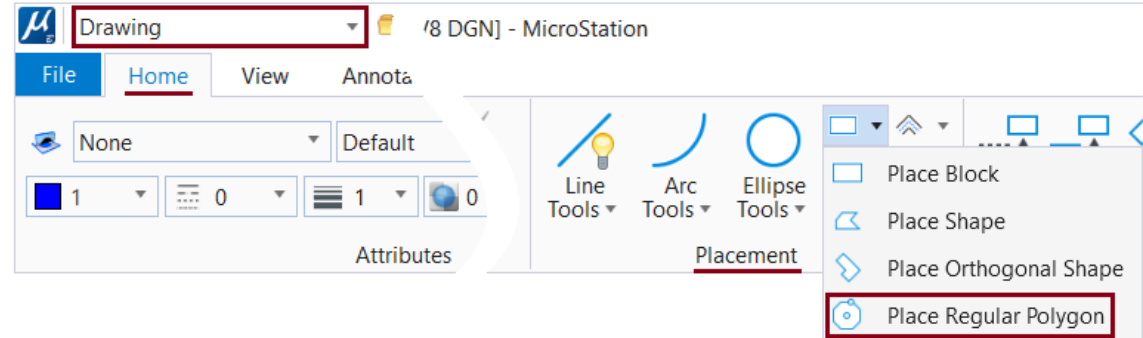
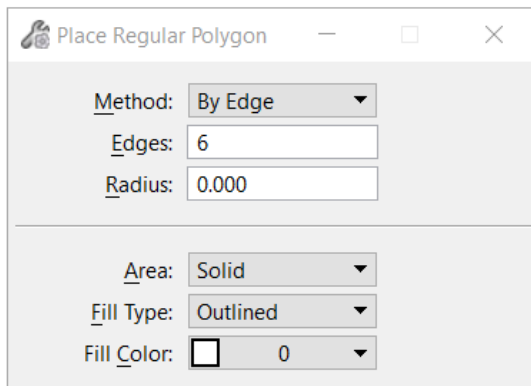

The hexagon to be placed is not in any of the standard planes (Top / Side / Front / View) so the compass needs to align to an arbitrary plane. The associated coordinate frame is called as an *Auxiliary Coordinate Frame (ACS)* for short).

4. Type shortcut **RA**. It stands for *Rotate ACS*.

① The prompt says '*Define X axis origin*'. Click the point **B**.  
This is the origin **O**.

② The prompt says '*Define X axis*'. Click the point **A**. *OA* now defines the direction of the positive **X** axis.

③ The prompt says '*Define Y axis*'. Click the point **C**. This is not necessarily the positive **Y** axis, but a direction close to it. The plane defined by the three points **A**, **B**, **C** now becomes the **XY** plane and the ACS gets placed. [If not visible] turn the *ACS Triad* setting **ON** in the *View Attributes* menu.

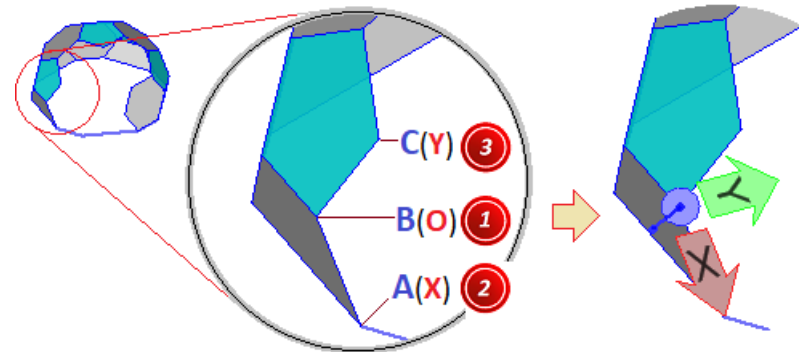

The ACS creation is now over and subsequent data points will now go to the Place Regular Polygon tool already active.

④ Click point **B** as the start of the hexagon edge. The hexagon is seen in dynamics, with a vertex sticking to the cursor.

⑤ Click point **A** as the end of the edge. This defines the edge and thus the size of the polygon and the ACS defines its plane and places it.

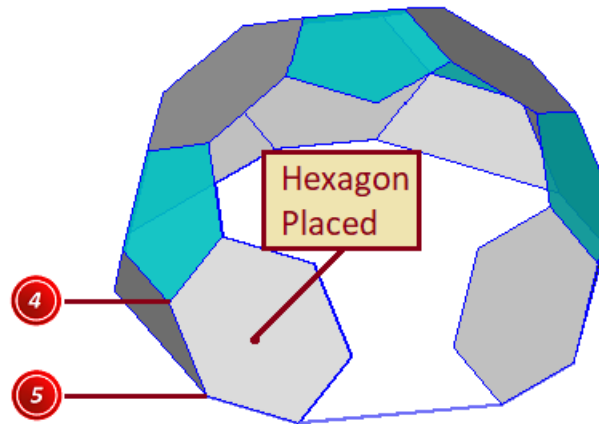
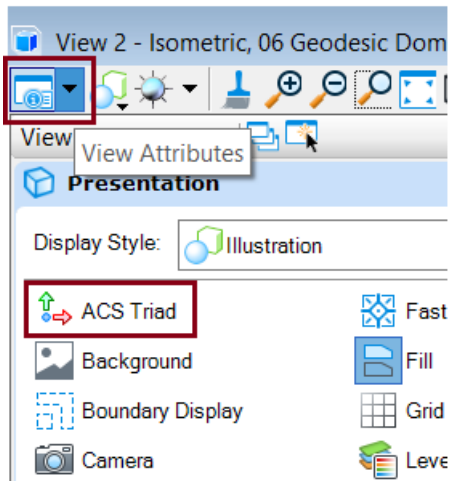

For all other missing polygons, these two steps – creation of ACS and placement of polygon are to be repeated.

5. Type Shortcut **RA** and click points **6 7 8**. This creates the ACS required for the next hexagonal panel.
6. Click points **9 10** to place the hexagon.

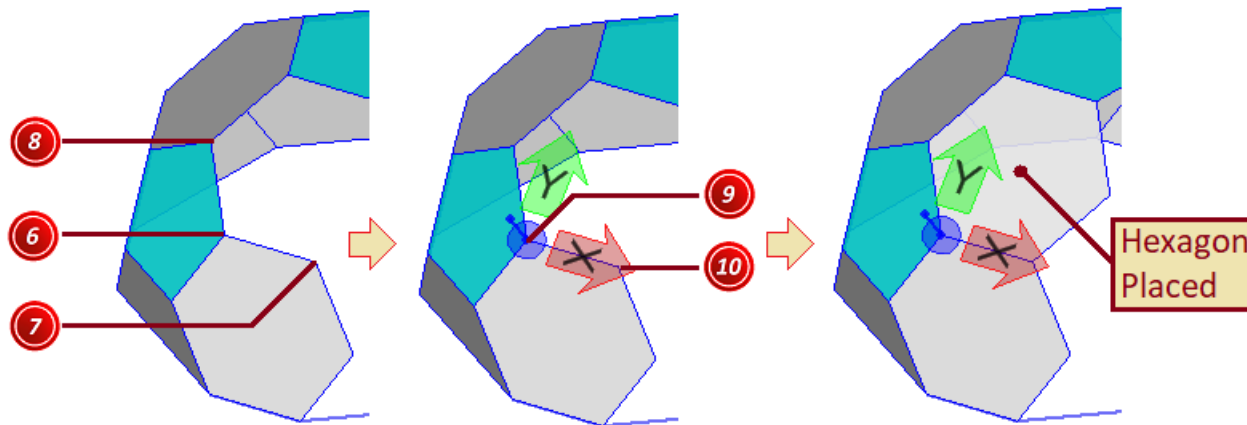

7. Similarly, place the remaining hexagonal panel.
8. From **Home** tab, **Attributes** section, set **Transparency** to **50** for the sky light glass pane.

9. In the Place Polygon Tool settings, set –
  - Edges = 5
  - Fill Color = 7 (light blue for glass)
10. Type shortcut **RA** and click points **1 2 3**. This creates the ACS required for the pentagon.
11. Click points **4 5**. This places the pentagonal sky light.

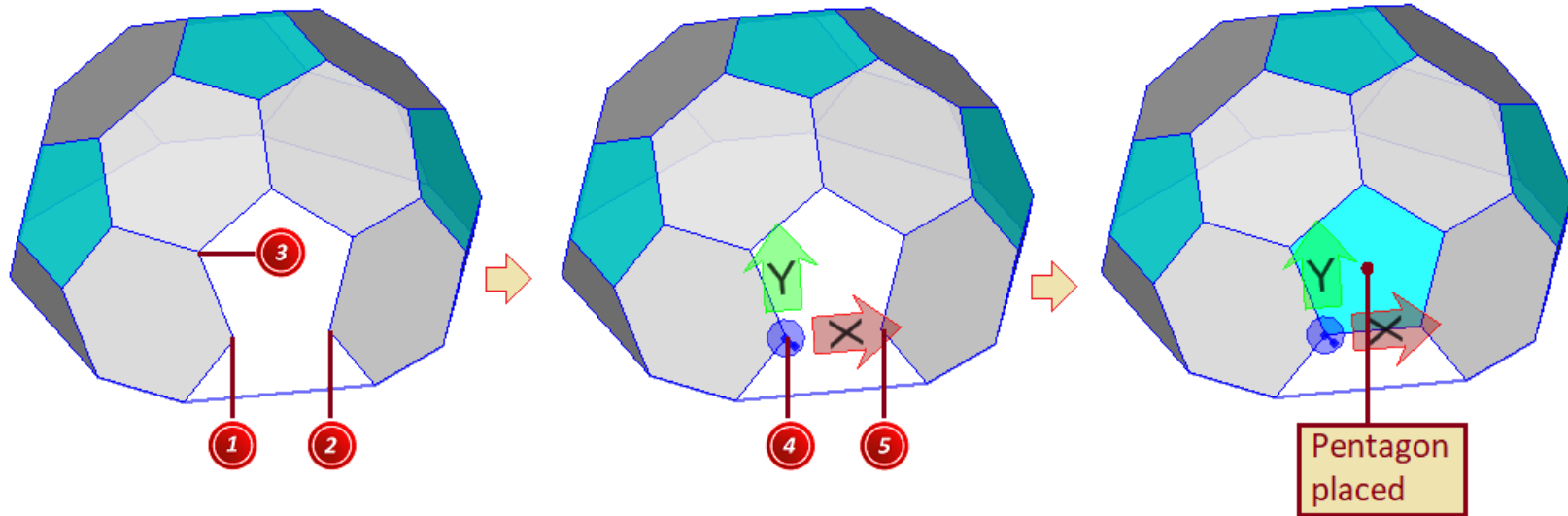

The ACS created above would be needed to place the text '**Entrance**'. Such ACSs that may come handy later, can be saved with shortcuts **WA** (**W**rite **A**CS) and recalled when needed with Shortcut **GA** (**G**et **A**CS) respectively.

12. Type shortcut **WA**. This brings up the Write to ACS dialog.
13. Type some name – say **Penta01** and click **OK**. This saves the ACS for later use.

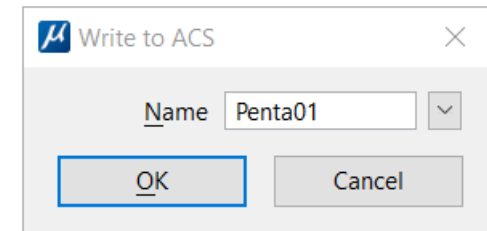

Just to test the recall, change the compass plane to say top with shortcut **T**.

14. From **Drawing Workflow**, **Annotate** Tab, **Text** section, start the **Place Text** Tool. Type the Text '**Entrance**'. This makes the text stick to the cursor. But it is currently not aligned to the plane of the pentagonal pane.

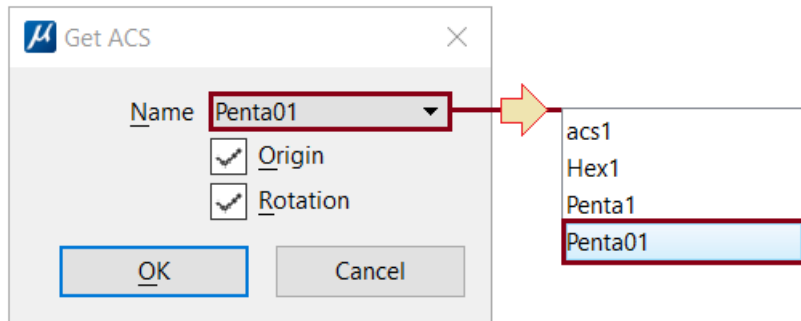

15. Type shortcut **GA**. *This opens the Get ACS dialog.*
16. Select the previously saved **Penta01** ACS and click OK.  
*This makes it active ACS. Note the compass and text are realigned to the pane.*
17. Snap and place the text at the center of the pane.

### ***What Next?***

Though this is called a basic course, it brings a lot of power and freedom of creating geometry in any location, orientation and plane in the design space. Precise numerical inputs and handy access to MicroStation tool settings and functionalities add to the precision and efficiency.

But AccuDraw has lot more to offer still! That will be covered in the advanced course.

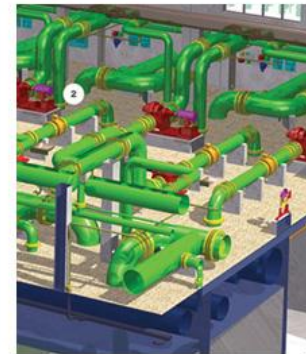
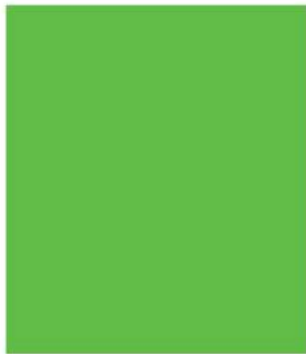

www.bentley.com

# More About AccuDraw

# What We will be Covering

- Review the Basics
- Model Setup
- Coordinate and Data Entry
- AccuDraw in a 2D Civil Context
- Basic Drawing Plane Rotation (3D AccuDraw)
- AccuDraw and the ACS
- AccuDraw and the Selection Tool
- Exploring All Things Z

# Review the Basics

Do you know...

- What the "Focus" is and how to manipulate it in AccuDraw?
- How to enter distances and angles in AccuDraw?
- What indexing is?
- What context sensitivity is?
- When and how to enter shortcuts?
- How to use the SmartLock?
- How to set and move AccuDraw's origin?
- How to select an ordinate of a point?
- How to use the "T" and "V" shortcuts?
- How to use the "RQ" shortcut?
- How to enter absolute coordinates?
- How to display a list of AccuDraw's shortcuts?
- How to display AccuDraw's settings?
- How to use AccuDraw's pop-up calculator?

# Model Setup

While not required, it may be useful to adjust the following settings...

## Grid Orientation

Setting the Grid's *Orientation* to ACS provides a quick visual cue as to the location of the drawing plane. The grid, of course, must be turned on from the View Attributes menu and be in a visible state with regard to the View's zoom factor.

The Design File Settings dialog box, where aforementioned setting is found, is accessed from the *Settings>Design File...* pull-down menu.

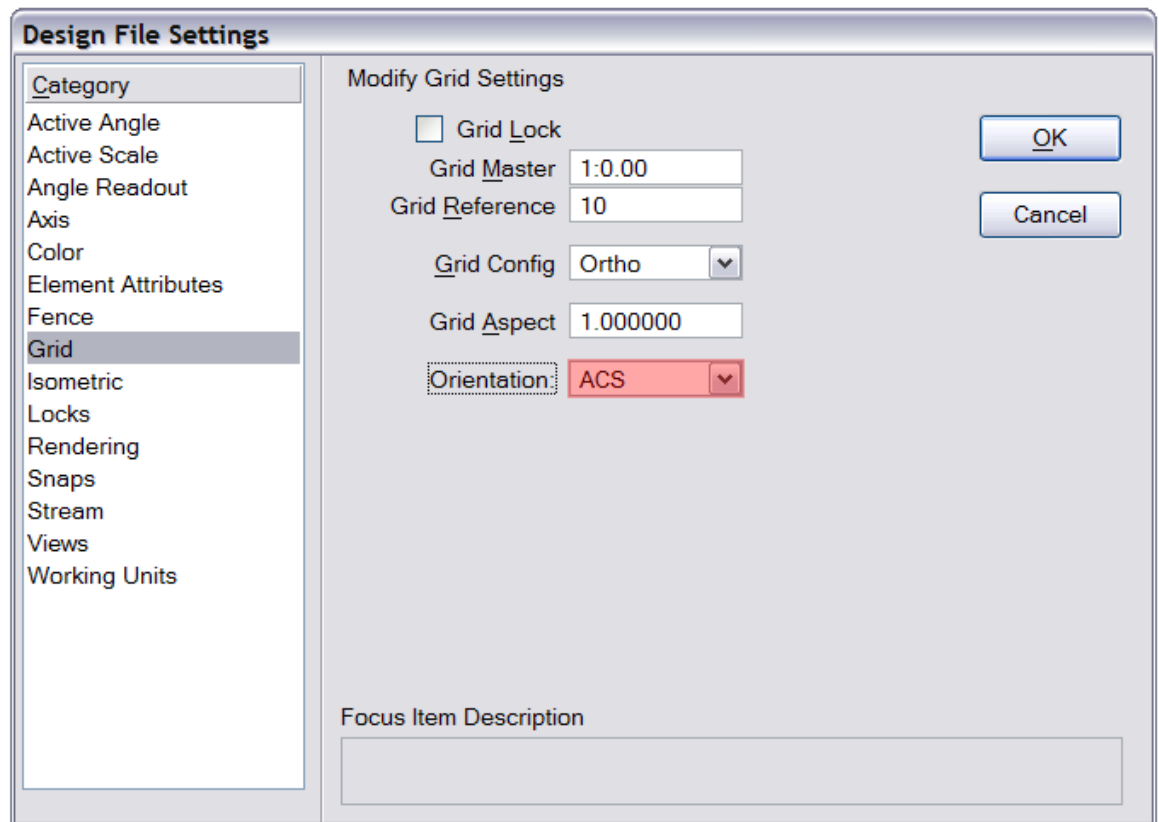

# Model Setup

Continued...

## Angle Readout

AccuDraw uses the Angle Readout settings.

Pictured to the right are Angle Readout settings that might be used in a civil context

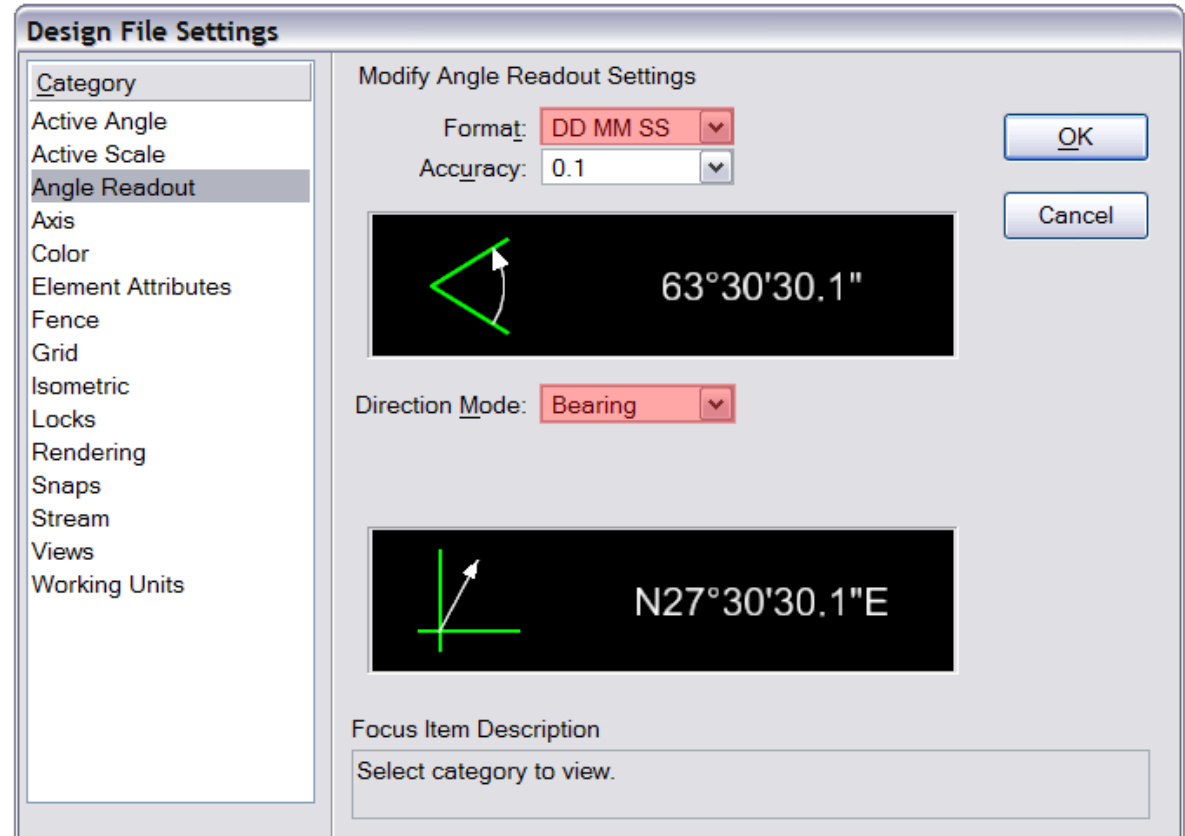

# Model Setup

Continued...

## Working Units

AccuDraw displays distances as defined in the Working Units Category of the Design File Settings dialog box.

Working units in the illustration to the right are set to read out in decimal feet to 1/100<sup>th</sup> of a foot. Inches will not be displayed because the Format is set to display only master units (MU).

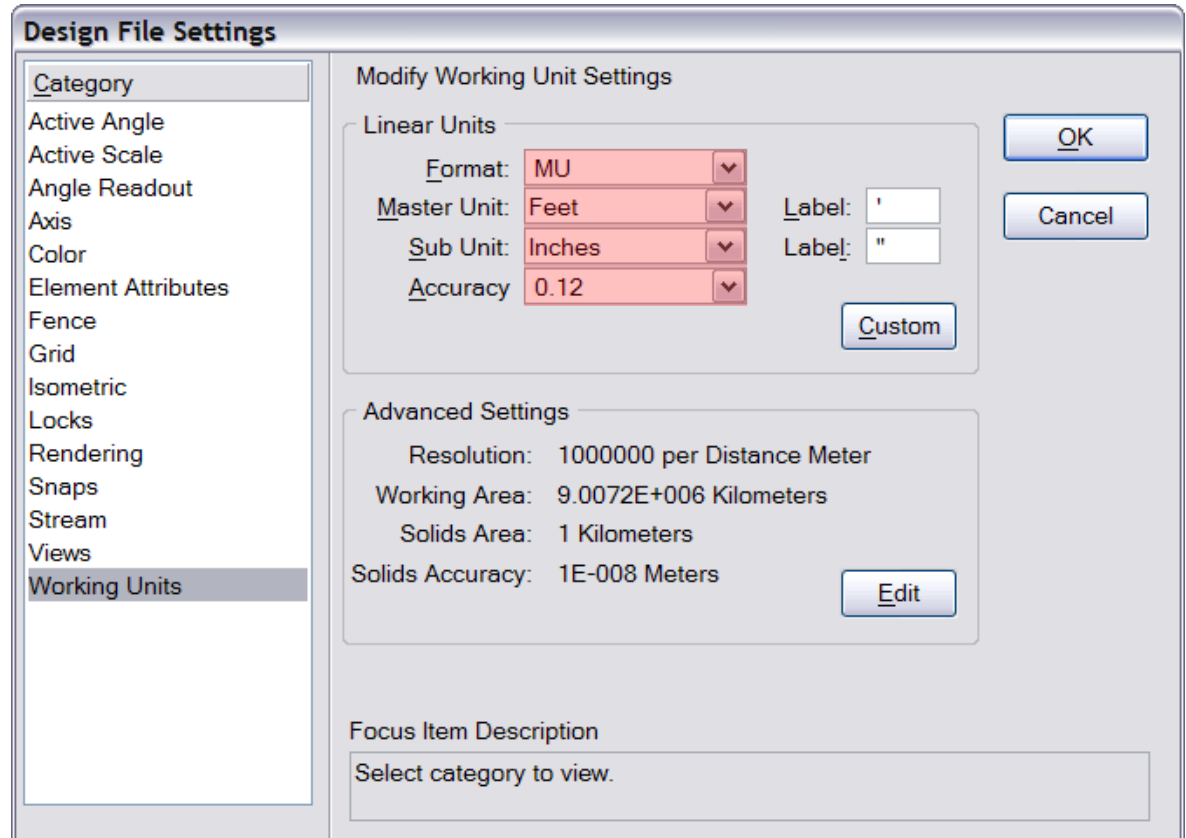

# Coordinate and Angle Entry

## Handy Stuff that's Worthy of Your Time...

### Degrees

When entering angles in DD MM SS format in AccuDraw, you can use either the caret symbol ( ^ ) or a semi-colon ( ; ) to indicate degrees.

Example: N89°59'42"E may be entered as **N89^59'42"E** or **N89;59'42"E**

### Using Angle Quadrants

Rather than entering the letters N, S, E, and W when entering bearings, you can enter quadrant numbers as a shortcut:

NE=1

NW=2

SW=3

SE=4

Example: N89°59'42"E may be entered as **1 89;59'42"**

# Coordinate and Angle Entry

Continued...

## Rather Not Use the Colon?

The shift key must be used to type a colon. This can be avoided by using one of the following substitutes:

- a semi-colon ( ; )
- an apostrophe ( ' )
- or two periods ( .. )

## Change the AccuDraw Window to N and E

Use these key-ins to switch AccuDraw between Northing/Easting and X/Y:

```
accudraw settings northeast  
accudraw settings xy
```

# Exercise

## Using AccuDraw 2D Civil Context

### Instructions

1. Open Property.dgn.
2. Check the design file settings.
3. Use the Property Description and AccuDraw to place the property lines
4. When using Place SmartLine, turn off *Rotate AccuDraw to segments*, in the tool settings dialog box.
5. Add distances and bearings with the Label Line tool.

### Questions

1. Why should *Rotate AccuDraw to segments* be disabled?
2. Do the lines close?
3. What is the acreage of the property?

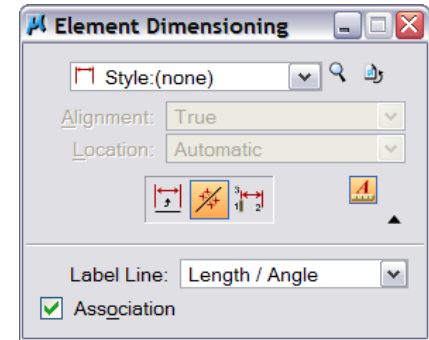
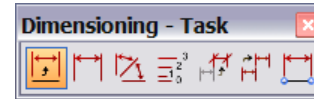

Pictured above and to the right (highlighted in orange) is the Label Line tool– which is a feature of the Dimension Element tool (highlighted on the left).

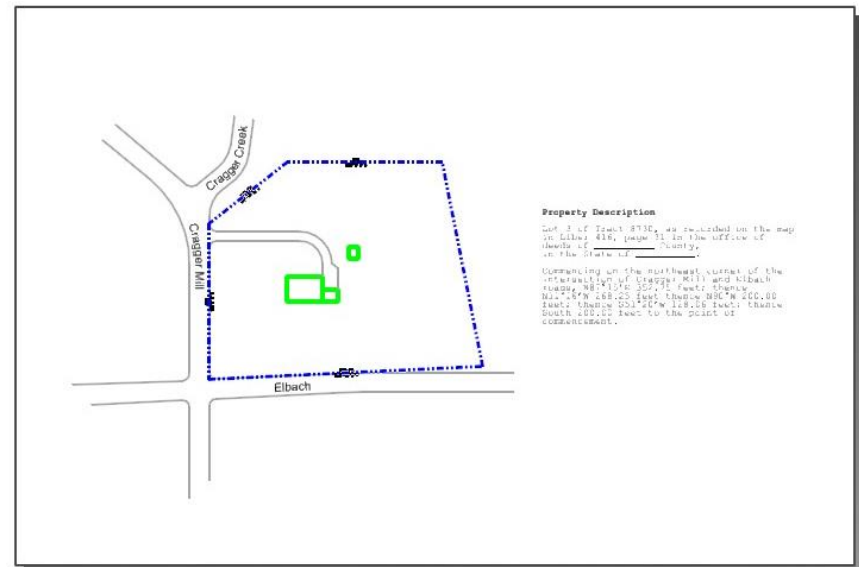

Completed Exercise

# Basic Drawing Plane Rotation

## Drawing a Shed with Planar Objects

### Set up:

1. Open 3D Accurdraw.dgn.
2. Check the Design File settings.
3. Rotate View 1 to *Isometric*.
4. From View Attributes select the *Transparent* display style.
5. Set the active color to 96 (medium gray).

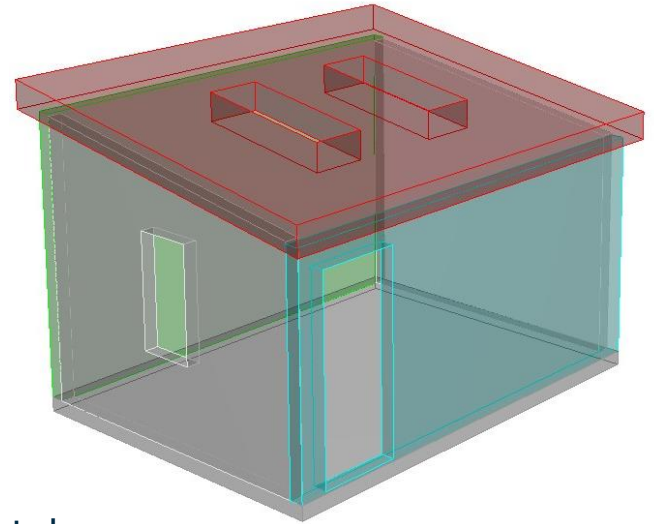

### Placing the Slab

Using AccuDraw and the Place Block command, draw 12' x 16' shape. Use AccuDraw's "P" (Data Point Keyin) shortcut to start the block at the ACS origin.

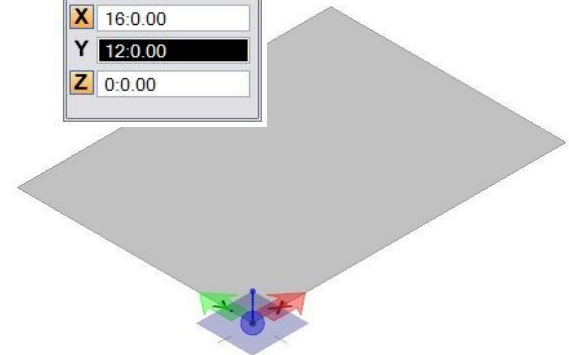
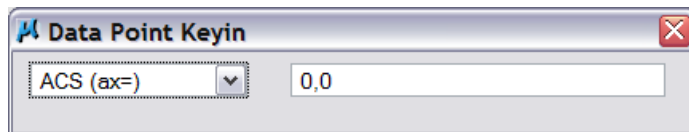

# Basic Drawing Plane Rotation

Continued...

## Placing the Back Wall

Again, using AccuDraw and the Place Block command:

1. Change the active color to 2 (green).
2. Place a data point at the back left corner of the slab.
3. Use the "F" shortcut to rotate AccuDraw to the Front plane.
4. Constrain the height of the wall (Y axis) to 10'.
5. Data point on the back right corner of the slab.

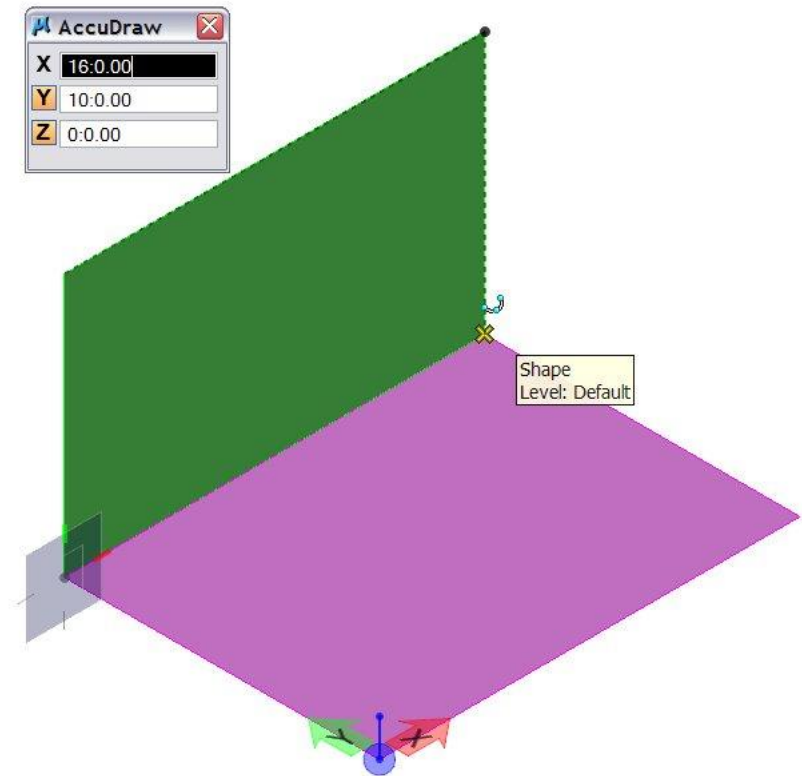

# Basic Drawing Plane Rotation

Continued...

## Placing the Front Wall

In like manner, place the front wall. The height of the front wall should be 8' and the color should be 7 (cyan).

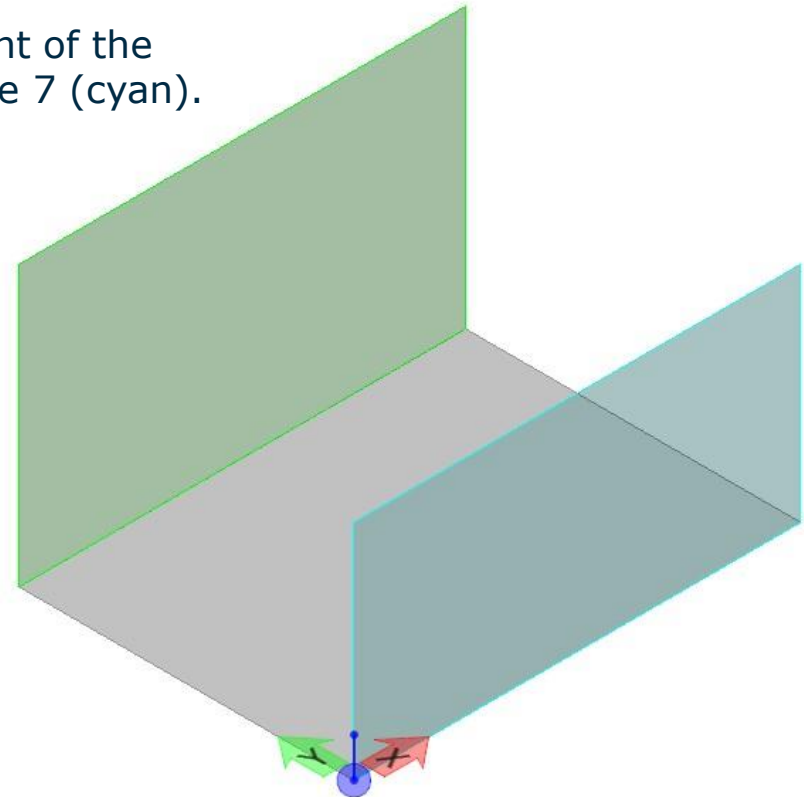

# Basic Drawing Plane Rotation

Continued...

## Placing the Side Walls

Use Place SmartLine to create a shape for the side walls.

1. Set the active color to 32 (light gray).
2. Start at Point 1. AccuDraw should be in the top drawing plane.
3. Lock the Z axis and hover over point 2. Notice how the X and Y ordinates of point 2 are used, but the Z ordinate of point 1 is retained.\*
4. Type "S" -- the side rotation shortcut, and complete the shape by entering vertexes at points 3 and 4 and closing the shape by returning to point 1.

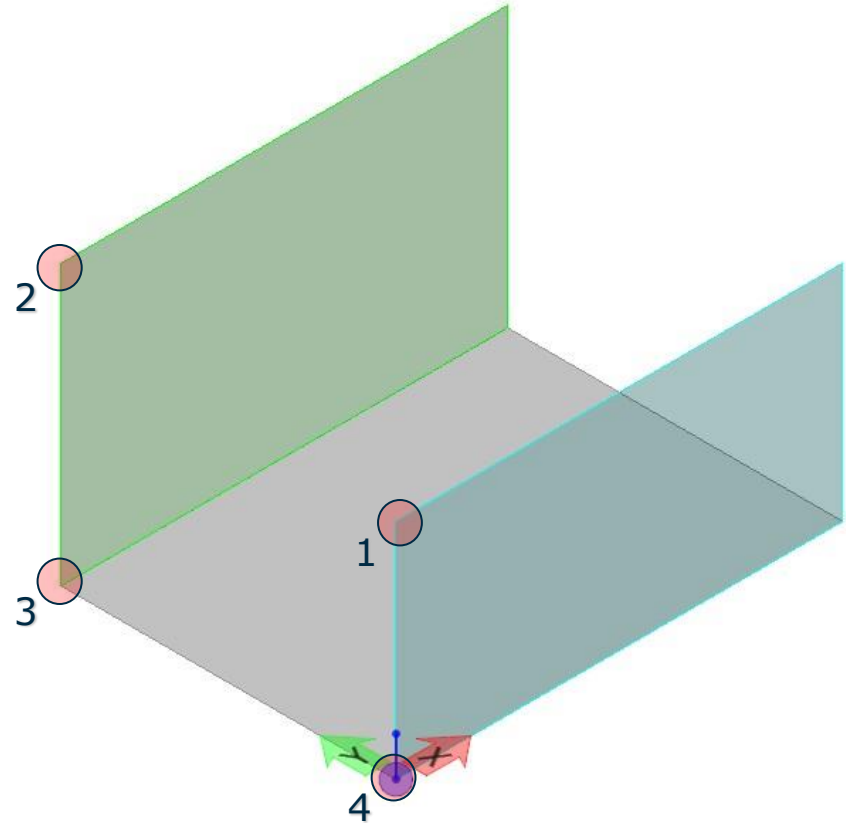

\* Locking the Z axis and rotating to the side drawing plane is not a necessary step to complete the shape, but is here to demonstrate “ordinate projection” and the “Side” rotation functionality.

# Basic Drawing Plane Rotation

Continued...

## Finish the Side Walls

After the first side wall is completed, create a second in like manner.

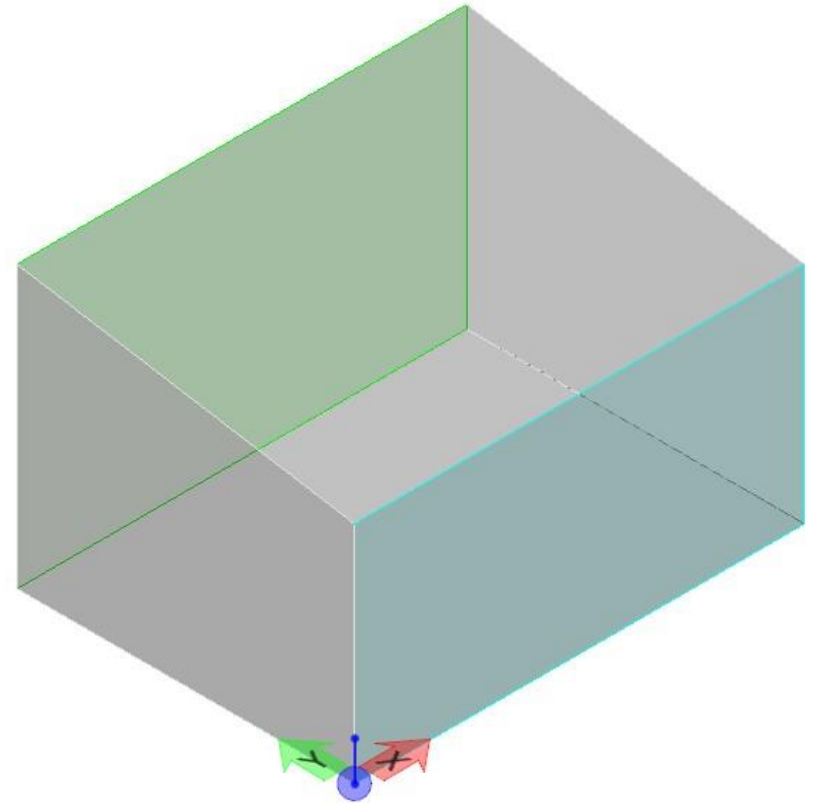

# Basic Drawing Plane Rotation

Continued...

## Add Doors and Windows

Using the Side and Front drawing planes (shortcuts "s" and "f") create shapes for a 7' x 3' door and a 2' x 4' window. Use AccuDraw to position the door and window shapes in the wall planes as illustrated.

Once the shapes are positioned, use the group hole  command (found on the *Groups* tool bar) to create openings in the walls.

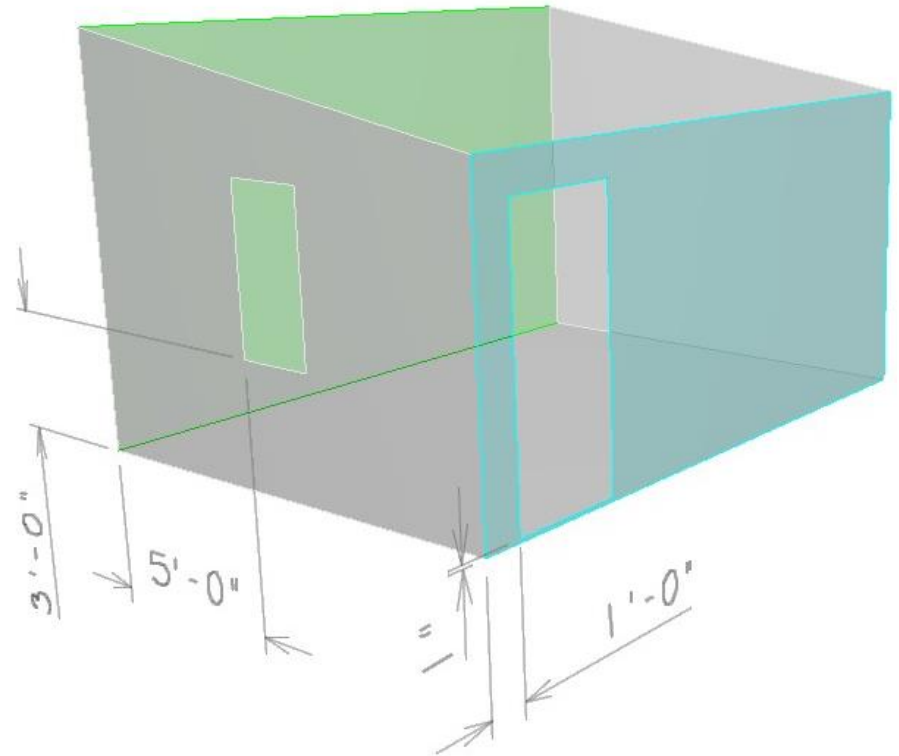

# AccuDraw and the ACS

## What is an ACS?

### 3D Auxiliary Coordinate Systems

An auxiliary coordinate system (ACS) is a coordinate system with an orientation, and/or an origin, different from those of the DGN file coordinates (the Global system). Although not exclusively a 3D concept, an ACS is most useful in 3D modeling as a drawing aid.

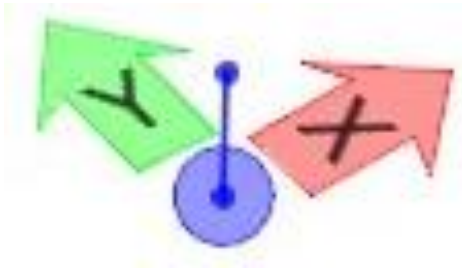

By using an ACS that corresponds to the location and orientation of a particular element, you can enter data points relative to parts of the model rather than the global origin.

Although using ACSs may seem complicated, AccuDraw uses them as a basic part of its 3D functionality. It is not necessary to learn much about ACSs to use them effectively with AccuDraw; however, we will explore some basic functionality which is useful in a 3D environment.

# AccuDraw and the ACS

## Defining a new Drawing Plane using the "RA" Shortcut

### Adding a Roof

Although we can use the Place Block command with the Method set to "Rotated" to quickly throw a shape on the roof, use the "Orthogonal" method and note the behavior of the command. Try the command with and without AccuDraw. What problems do you encounter?

Often it is useful to work in a design plane other than the Top, Front or Side. AccuDraw's "RA" (Rotate ACS) shortcut enables us to quickly define a new design plane based on three points.

After we define a new drawing plane we'll add the roof.

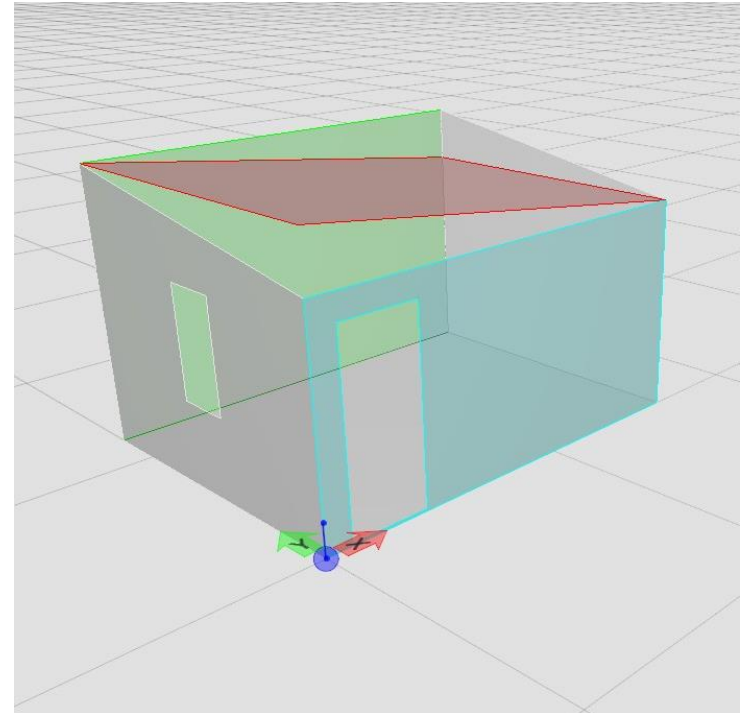

**Yikes!** We would have had a better result if we had rotated our drawing plane first using AccuDraw's "RA" shortcut.

# AccuDraw and the ACS

Continued...

## Using the "RA" (Rotate ACS) Shortcut

The "RA" shortcut may be used at any time. You do not need to be in the middle of a command to use it, although that is permitted. Use the following steps to create a new ACS in the roof plane of the shed:

1. Make sure AccuDraw has the focus (clicking on it or pressing the f11 key will do this).
2. Key in "RA" or "ra".
3. Define X axis origin at point 1
4. Define X axis (any point on the axis). We will use point 2.
5. Define Y axis (any point on the axis). We will use point 3.

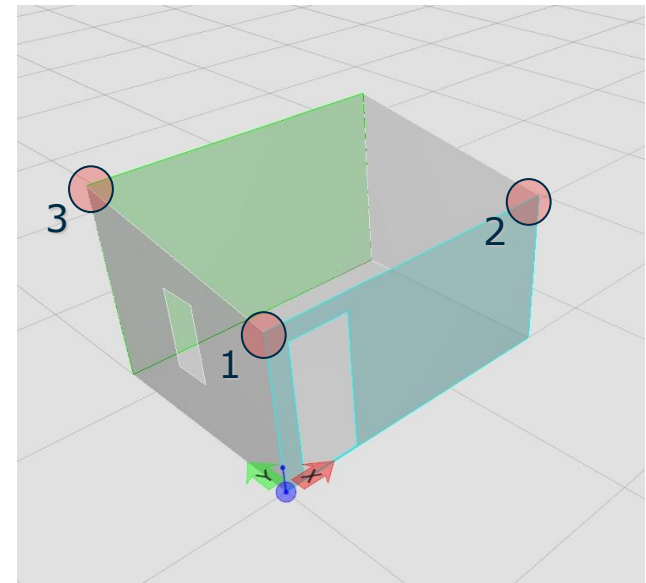

# AccuDraw and the ACS

Continued...

## Complete the Roof

The ACS triad will display the origin and orientation of the new drawing plane. Additionally, if configured to do such, the grid will also align with the drawing plane.

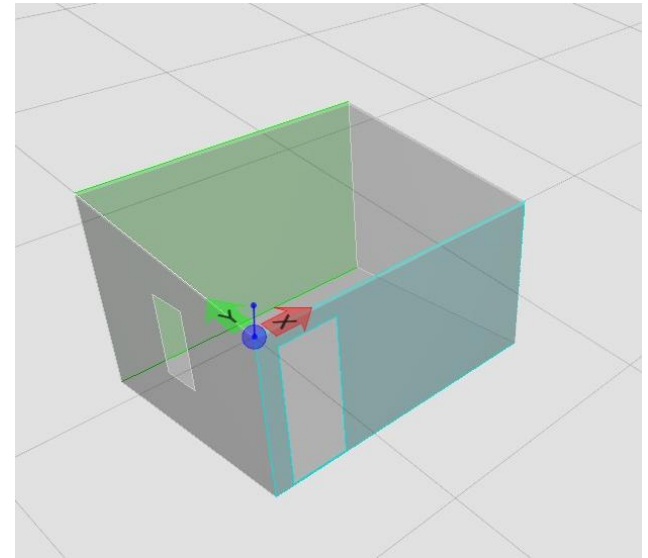

Your newly created drawing plane should look something like this.

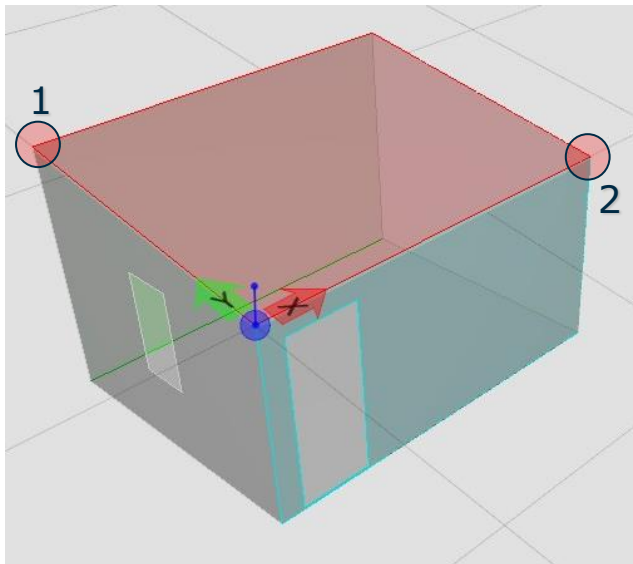

Complete the roof by using the Place Block command:

1. Set the active color to 3.
2. Select points 1 and 2.

# AccuDraw and the ACS

## Save the ACS using the "WA" Shortcut

### The "WA", "O" and "RC" shortcuts

The "WA" (Write to ACS) shortcut takes the current drawing plane and saves it as a named ACS. Once this has been done, the named ACS can be recalled through AccuDraw or through the Auxiliary Coordinates dialog.

**CAUTION:** The current location and orientation of the AccuDraw Compass will be used to define the new ACS. If you have been working in an unsaved ACS (as we have) it may be necessary to use the "O" (Origin) shortcut to positively define the origin and "RC" (Rotate to current ACS) to re-align the axis.

### Create a named ACS

Use the WA shortcut to create an ACS named "Roof".

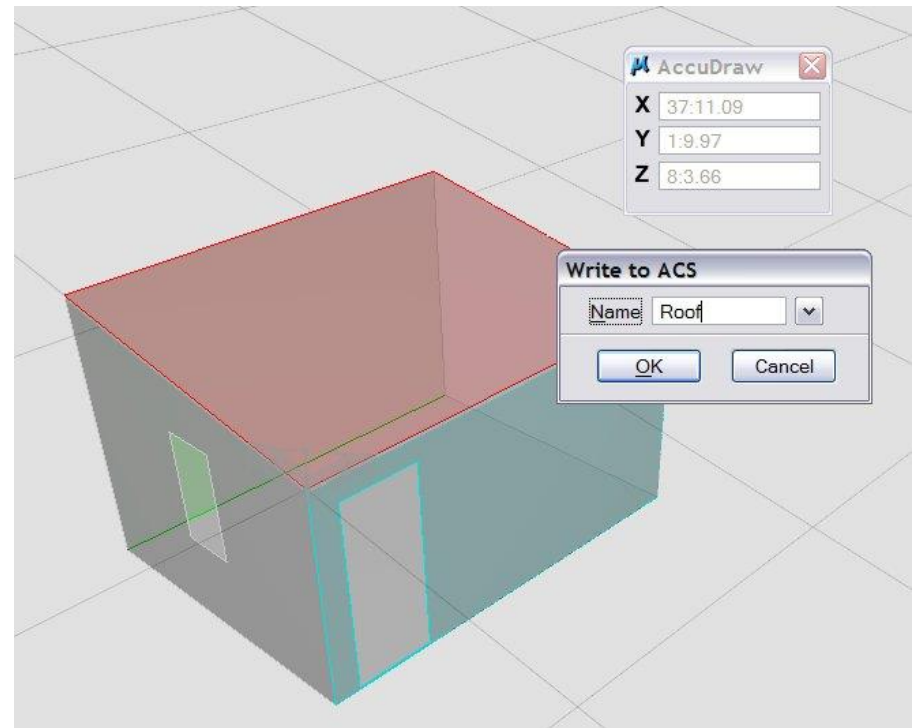

# AccuDraw and the ACS

## The Auxiliary Coordinates Dialog Box

### Managing Coordinate Systems

The Auxiliary Coordinates Dialog Box (accessed from the *Utilities* pull-down menu) is used to manage user-defined coordinate systems. As you can see, the "Roof" coordinate system we saved is here. The main window of the dialog box is broken into two sections:

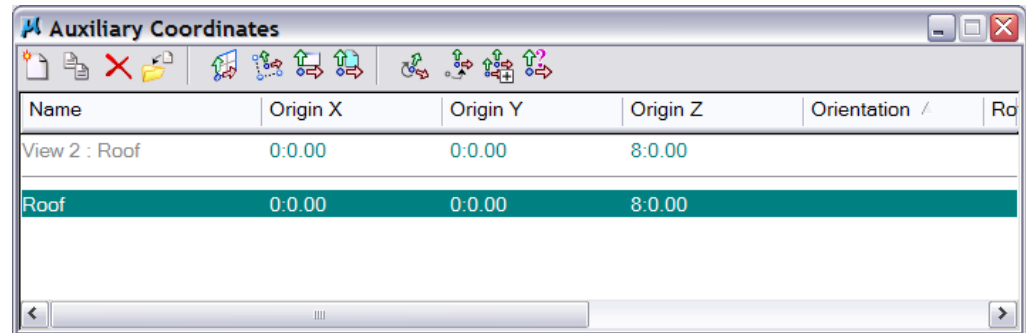

The top section, displaying "View 2: Roof" displays information about the last view in which a data point was entered. Different views can implement different coordinate systems. Coordinate systems can even "follow" your view. This feature is controlled by the "Toggle View Independent" option in the Auxiliary Coordinates right-click menu.



The bottom section holds a list of named coordinate systems that have been saved. Double clicking a named coordinate system will apply it to the current view.

To reset a view to the Global Coordinate System, right-click the view name in the top section of the dialog box and select "Reset To Global".

# AccuDraw and the ACS

## Changing Coordinate Systems

### Reset, Create and Restore Coordinate Systems

1. From the Auxiliary Coordinates dialog box, reset your current view to global.
2. Next use the Copy ACS tool  to create a copy of the current (Global) ACS.
3. Name the new ACS "Global".
4. Switch between different systems by double clicking them in the Auxiliary Coordinates dialog box.
5. Try using the Select ACS tool  to select a different ACS.

### Use AccuDraw's "GA" Shortcut to Recall an ACS

1. Once again, from the Auxiliary Coordinates dialog box, reset your current view to global.
2. Close the Auxiliary Coordinates Dialog box.
3. In AccuDraw, enter the "GA" Shortcut.
4. Restore the ACS "Roof". Be sure both *Origin* and *Rotation* are checked.

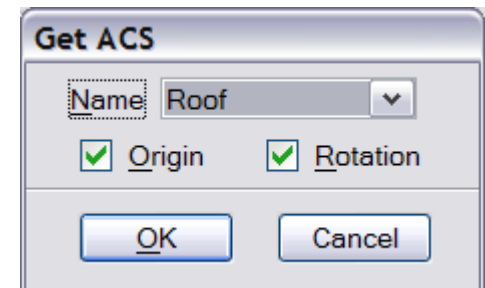

# AccuDraw and the ACS

Continued...

## Add Skylights in the Roof Plane

Create two 2' x 5' shapes for skylights and position them in the roof plane. Use the Keypoint Snap and Keypoint Snap Divisor to position the skylights evenly in the roof plane. The Keypoint Snap Divisor dialog box is displayed by using the AccuDraw's "K" shortcut.

Once the shapes have been positioned, use the group hole tool to punch holes in the roof with the shapes.

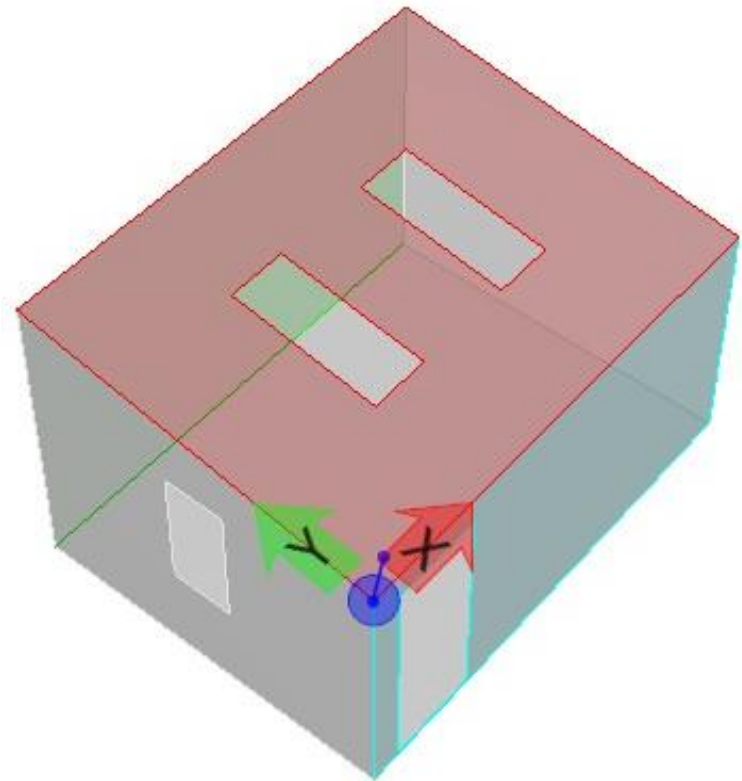
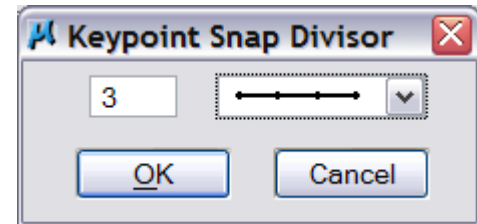

# Modifying Elements with AccuDraw

## The Element Selection Tool with AccuDraw

### Create a Roof Overhang

1. With the Element Selection tool select the roof plane.
2. Click on a corner handle – Note how AccuDraw aligns itself with element being modified.
3. Using AccuDraw add 6" of overhang to each edge of the roof plane.

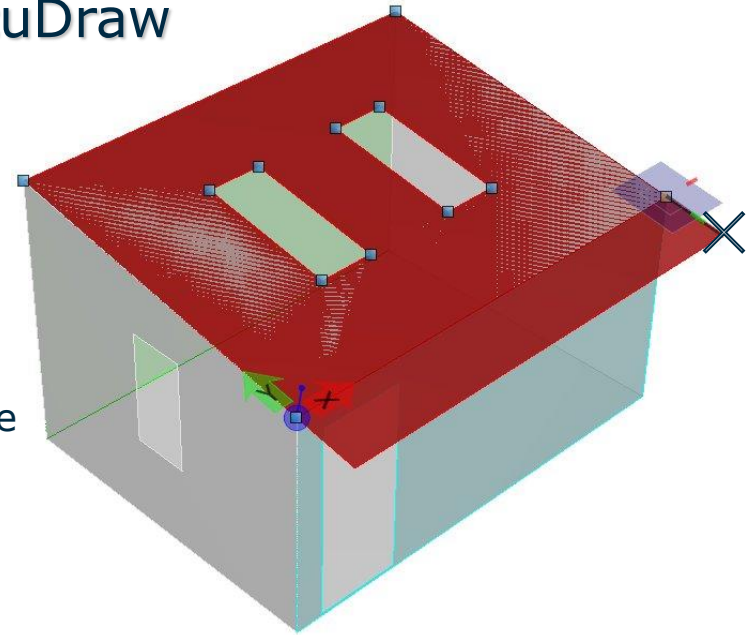
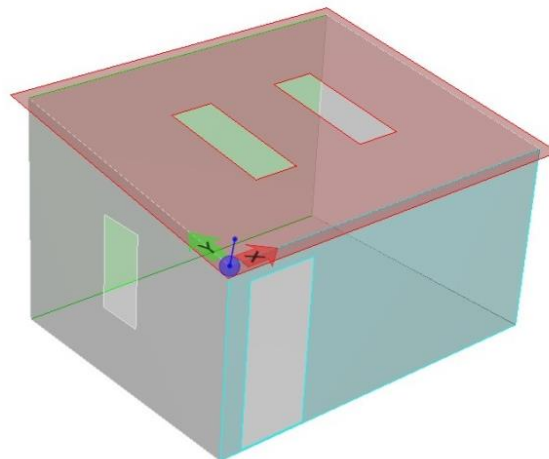

# Modifying Elements with AccuDraw

Continued...

## Solidify the Planar Elements

Use the Solid by Extrusion tool  to add thickness to the roof, walls and slab. At the outset, do not check any boxes in the tool settings and leave the scale values set to one.

Starting with the roof, extrude the roof plane straight up 1'. You will have to adjust AccuDraw's drawing plane in order to do this as initially AccuDraw will orient itself perpendicular to the roof plane.

Once the roof is done, using Solid by Extrusion tool, "thicken" the walls of the shed by 6" to the inside and thicken the floor slab downward by 6". This time in the tool settings, check and set the distance to 0:6. Also make sure *Orthogonal* is checked.

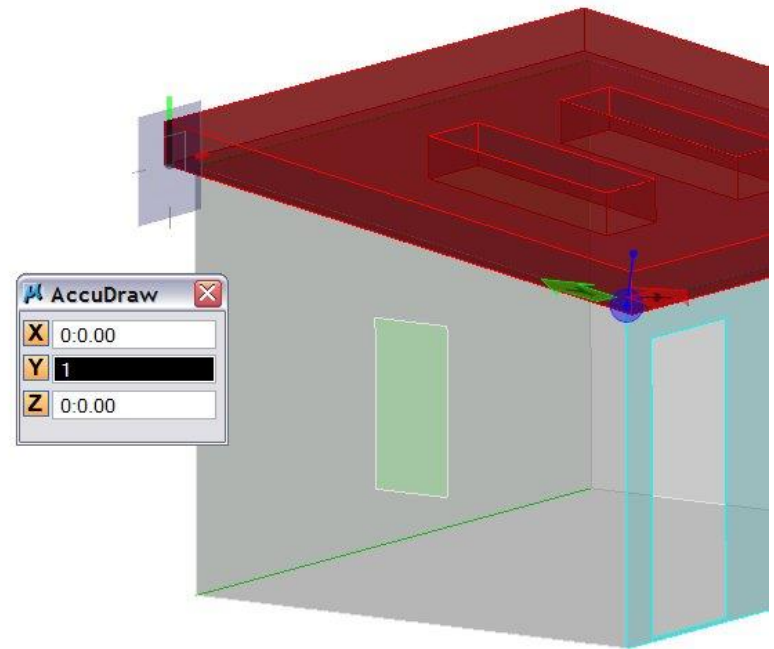

Note how the AccuDraw compass is not perpendicular to the roof plane.

# Modifying Elements with AccuDraw

## Finishing the Shed and More to try...

### Continuing with the Selection Tool...

Using the selection tool, shorten the two side walls by 6" on each end so they won't intersect with the front and back wall. You may use AccuDraw or snaps to do this.

### More to try...

Using AccuDraw and the Selection tool, select a handle on the corner of the floor slab and make it 2" thicker.

Select the wall with the door opening. Activate the four handles on the door. Use AccuDraw to move the door opening 2' toward the center of the wall.

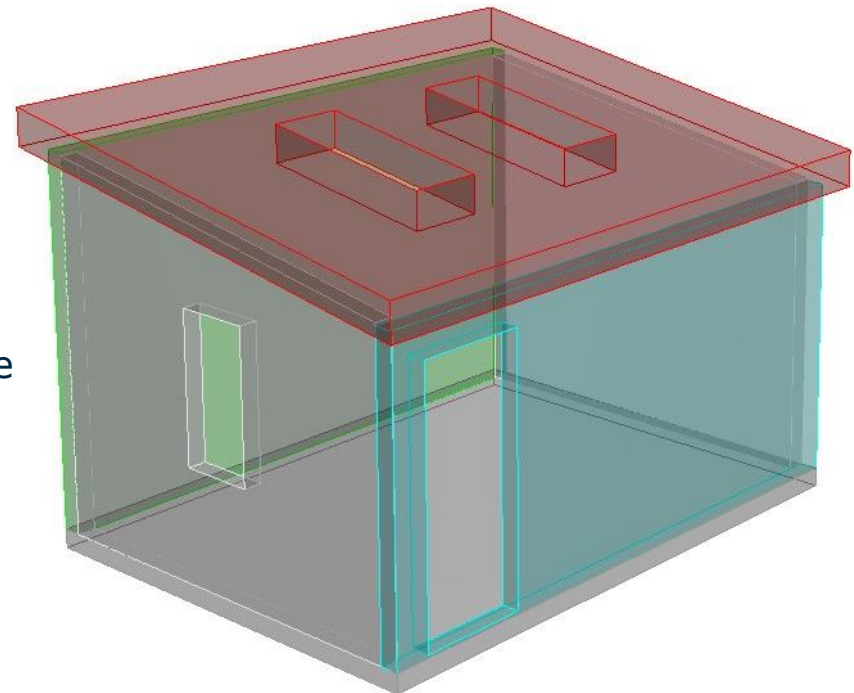

# Exploring all Things Z

## Active Depth:

Active depth is a view-oriented method of dealing with Z ordinates. The following exercise explores how Active Depth works.

1. Open the file All Things Z.dgn.
2. Be sure *AccuDraw*, *ACS Plane Lock* and *ACS Snap Lock* are turned off.
3. In view 1 (which is rotated to "Top") place a cyan block around the cube.
4. Continuing in view 1 select the Set Active Depth  command and click in View 1.
5. In the front or right view, select a point on the midpoint of a red line to set a new active depth for view 1. Notice the top view's ACS has changed and is now set to following the view. This setting may be toggled off or the view may be reset to Global through the Auxiliary Coordinates Dialog box.
6. Continuing in the top view, draw a magenta box around the cube and cyan box.
7. Finally, reset the view's ACS to Global.

## Explore some more

Try setting an active depth in the front, right and isometric views. What happens? Note how active depth is always "aligned" with the view.

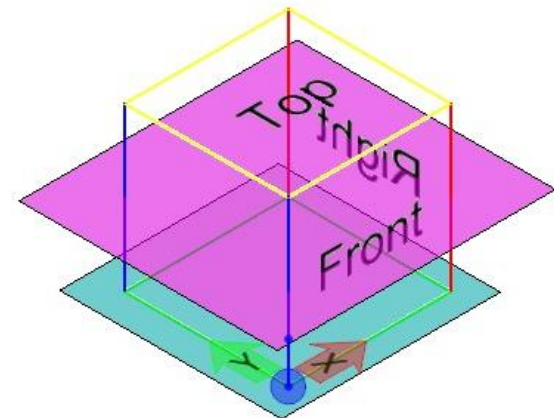

# Exploring All Things Z

## ACS Plane Lock:

*The ACS Plane Lock may be activated from the status bar or by invoking the AccuDraw shortcut “LA”.*

The *ACS Plane Lock* forces data points to lie on the ACS plane. In the absence of AccuDraw, this is what happens– even with the *ACS Plane Lock* is not engaged. There are exceptions however. The following exercise demonstrates the difference this lock makes when placing a circle.

### Continuing in All Things Z.dgn:

1. Delete the cyan and magenta blocks. Ensure the ACS of all views is set to Global. Disengage the *ACS Plane Lock*. Turn AccuDraw off.
2. In View 3, place a cyan circle using the center method without a constrained radius/diameter. Use point 1 for the center of the circle and point 2 to define the radius (see illustration below).
3. Perform the same operation again, but this time use a magenta circle and be sure the *ACS Plane Lock* is engaged.

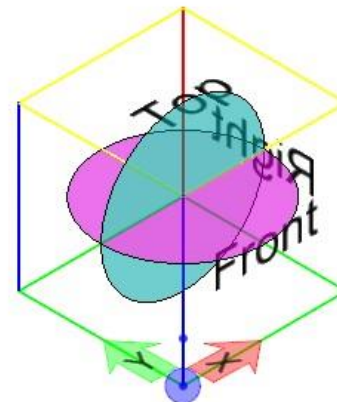
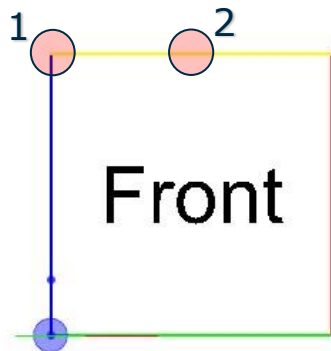

The isometric view of your completed exercise should look like this.

# Exploring All Things Z

*The ACS Plane Snap Lock may be activated from the status bar or by invoking the AccuDraw shortcut “LS”.*

## ACS Plane Snap Lock:

The *ACS Plane Snap Lock* forces snapped data points to lie on the ACS plane. With respect to the ACS, the data point's X and Y ordinates are maintained, but the Z ordinate is forced to a value of zero.

## Continuing in All Things Z.dgn:

1. Delete the cyan and magenta circles you just created. Be sure both the *ACS Plan Snap Lock* and the *ACS Plane Lock* are disengaged.
2. In View 2 (Isometric), place a cyan circle using the center method without a constrained radius/diameter. Use point 1 for the center of the circle and point 2 to define the radius.
3. Perform the same operation again, but this time use a magenta circle and be sure the *ACS Plane Snap Lock* is engaged.

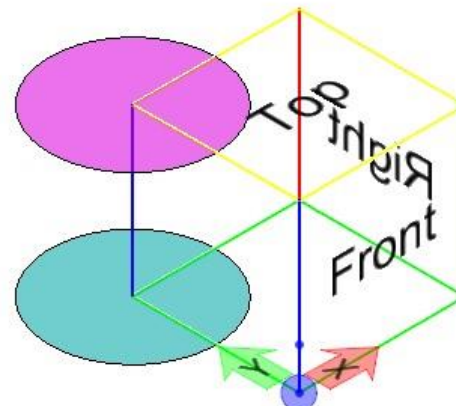
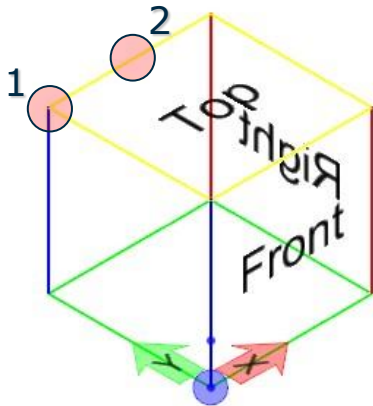

The isometric view of your completed exercise should look like this.

# Exploring All Things Z

## Sticky Z

When *Sticky Z* is engaged the Z axis will remain locked through consecutive operations. Normally, locks are cleared when you enter a data point. This setting is useful, for example, where you want to draw on the one plane (that is, you want to lock  $Z=0$ ), while snapping to elements that are on another plane. With *Sticky Z Lock* enabled, the Z value will remain locked until you turn it off.

*Sticky Z* is enabled by checking the "Sticky Z Lock" on the AccuDraw Settings' operation tab. When engaged, the AccuDraw Compass will display with an inner circle or square.

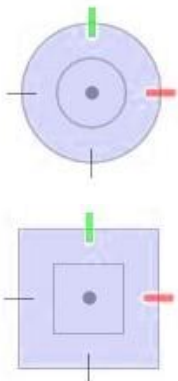

Appearance of AccuDraw's compass when Sticky Z is engaged.

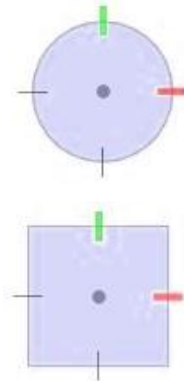

Appearance of AccuDraw's compass when Sticky Z is disengaged.

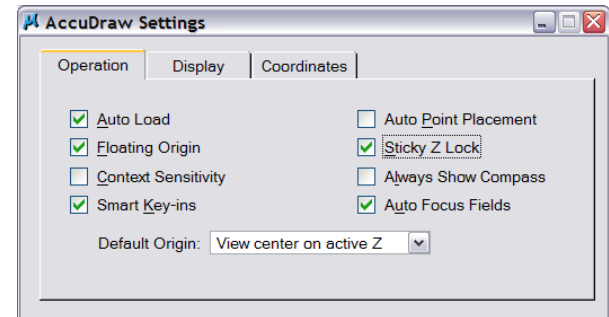

Operation tab of the AccuDraw Settings dialog box. Use the shortcut "GS" to display this dialog box.

# AccuDraw Shortcuts

## **V = View Rotation**

Rotates the compass to the View axes.

## **T = Top Rotation**

Align the compass with the axes in a standard Top/Bottom view.

## **F = Front Rotation**

Align the compass with the axes in a standard Front/Back view.

## **S = Side Rotation**

Align the compass with the axes in a standard Left/Right view.

## **B = Base Rotation**

Rotates the drawing plane to align with the active ACS, or to a rotation of the view.

## **E = Cycle Rotation**

Rotates between three main planes: top, front, and side. <E> also works when your original plane is an ACS or context rotation, so you do not have to use RX, RY to rotate to a 90° plane from the ACS axis.

## **Z = Toggle Z lock**

Toggles the locking of the Z field.

## **LP = Lock ACS Plane and ACS Plane Snap**

Toggles ACS Grid Plane lock, which toggles the ACS Plane and ACS Plane Snap locks, and the Grid view attribute for all views.

## **LA = Lock ACS Plane**

Toggles ACS Plane lock.

## **LS = Lock ACS Plane Snap**

Toggles ACS Plane Snap lock.

## **LZ = Sticky Z Lock toggle**

Toggles Sticky Z Lock, which can be used in conjunction with ACS Plane Snap Lock to force a series of snap points to lie on the active ACS' XY plane (Z=0) or can be used without the ACS plane.

# AccuDraw Shortcuts

## **RA = Rotate to ACS**

Used to permanently rotate the drawing plane. Because it rotates the current ACS, this rotation will still be active after the tool in use is exited. If on, the tool setting Use Current Origin causes the drawing plane origin to be used as the x-axis origin, thereby eliminating the need to enter an extra data point. Of course, in many cases it is desirable to be able to define the x-axis origin at a different location than the drawing plane origin.

## **GA = Get Saved ACS**

Lets you select a saved Auxiliary Coordinate System.

## **WA = Write (Save) ACS**

Lets you save the drawing plane alignment as an ACS.

## **RC = Rotate to Current ACS**

Rotates the drawing plane to the current ACS.

## **RE = Rotate to Element**

Rotates the drawing plane to match the orientation of a selected element.